



OP NOTICE TO SHIPPING No. N-1-2010 (Revision 1)

Vessel Requirements



April 16, 2010

OP NOTICE TO SHIPPING No. N-1-2010, Rev. 1

To: Steamship Agents, Owners and Operators

Subject: Vessel Requirements

1. Effective Date and Cancellation

This Notice is effective on the date of issue and cancels OP Notice to Shipping No. N-1-2010, which was revised to modify several paragraphs and incorporate new content.

2. Purpose and Scope

a. The purpose of this document is to inform the shipping community of the procedures and amplifications necessary to implement the Maritime Regulations for the Operation of the Panama Canal (MROPC). **Please be advised that non-compliance with Panama Canal rules and regulations may subject vessels to unnecessary delays or denial of transit.** The Panama Canal Authority (ACP) may order deviations from these rules if special circumstances so warrant. Please refer to the Table of Contents on pages ix through xi.

b. Some of the changes in this revision include:

- (1) The addresses for drawing submittals were modified on pages *v* and *vi*.
- (2) File format for drawings are defined in Paragraph 2 i (5), on page 13.

(3) The cargo securing manual (container section) was added to the list of documents that are to be submitted to the Admeasurement and Billing Unit prior to transit, on page 13.

(4) The requirement for enclosed bridge wings to have blade type wipers located also on the forward and aft windows at Conning Positions 4 and 5 was added to Paragraph 4 b (4), on page 18.

(5) The requirement for bridge wings to be provided with a clear, unobstructed passageway of at least 3.93 feet (1.2 m) wide was added to paragraph 4 c, on page 18.

(6) Paragraph 4 d (6) was modified on page 19 to establish that no equipment or instrumentation shall block the close approach to the forward windows at Conning Positions 1, 2 and 3 and from the forward to after portions of the bridge wing ends at Conning Positions 4 and 5; and a minimum of 3.28 feet (1 m) clearance from consoles or obstructions should be provided in these areas.

(7) Paragraph 10 e (1) was modified to indicate that all vessels shall have, weather permitting, both an accommodation ladder and a pilot ladder rigged and ready for use upon arrival in Canal waters, on page 37.

(8) Subsection 13 d. Calculations of PC/UMS for Vessels not Designed to Carry Containers on Deck was added on page 45.

(9) Finally, Annex 1 (Embarking or Disembarking during Transit) was added on page 63.

The following are the changes made to the original Notice to Shipping No. N-1-2010 (*Vessel Requirements*) that was published January 1, 2010.

(1) The definitions of *Full Container Vessel*, *TEU* and *Maximum Allowable Response Time* were added on pages 1 and 2.

(2) Paragraph 2.f (d) was modified to include the requirement of providing information regarding the Panama Canal ballast condition detailed output, on page 5.

(3) Tables II, III and IV were updated on pages 9, 10 and 11, respectively.

(4) The title of Paragraph 4.f (2) was modified and paragraph (d) was deleted, on page 21.

(5) Paragraph 4.f (3) (*Controllable pitch propeller indicators*) was added and the former paragraph was changed to 4.f (4), on page 22.

(6) Paragraph 4.k was modified to state that vessels of less than 150 gross tonnage shall be fitted with a steering compass and have means for taking bearings, on page 23.

(7) Subsection 4.o was replaced with new subsection, titled *Main Propulsion Systems*, on page 24.

(8) New subsection 4.q (*Steering Gear*) was added on page 26.

(9) Paragraph 5 (4) was modified to establish that inspections will be performed during daylight hours, on page 27.

(10) Paragraph 8.a (15) was modified to indicate the new position for chocks and bits, on page 32.

(11) Paragraph 9.d was modified to state that the master shall inform the ACP Boarding Officer whether or not the vessel complies with the requirement, on page 34.

(12) Section 12 (*Admeasurement System for Full Container Vessels*) was updated to include, among other issues, the new TEU measurement that replaces the current PC/UMS tonnage measurement for full container vessels, on page 42.

(13) Subsection 13.d (*Calculation of PC/UMS for Vessels not Designed to Carry Containers on Deck*) was deleted.

(14) Paragraph 16.a was modified to increase the minimum hour requirement from 48 to 96, on page 45.

(15) Subsections 14.h (*Reporting Shipments of Hazardous Wastes*), 14.i (*Reporting Radioactive Cargoes*) and 14.j (*Coverage requirements for transiting vessels carrying radioactive cargoes*) were updated on pages 48 and 49.

(16) Subsection 16.i (*Reporting Radioactive Cargoes*) was updated on page 49.

(17) Paragraph 16.j (1) was updated on page 49.

(18) Section 19 (*Hot Work Performed On Board Vessels*) was updated on page 53.

(19) Section 23 (*Emergency Source of Electrical Power*) was added on page 57.

(20) Former section 23 (*Sanitary Facilities and Discharging Vessel Wastes, Ballast and Sewage*) was divided in section 24 (*Sanitary Facilities and Sewage Handling*) and section 25 (*Discharging of Vessel Wastes, Oily Bilge Water and Ballast Water*), on pages 57 and 58.

(21) New section 26 (*Emergency Escape Breathing Devices*) was added on page 58.

(22) Former sections 20 and 21 changed to section 27 (*Smoking Prohibition in Canal Waters*) and section 28 (*Proper Display of the Panamanian Flag*), on page 59.

3. Organization and Responsibility

The *Operations Department* (272-4500, fax: 272-3892), under the Executive Vice President of Operations, is the organizational unit of the Panama Canal Authority responsible for the control of maritime traffic through the Canal and its terminal ports, and through which all ACP services to shipping are handled. Following is a summary of the Operations Department units which, due to their functions, often require contact with agents, operators and owners:

a. The *Transit Operations Division* (272-4211, fax: 272-4288), headed by the Transit Operations Division executive manager, is responsible for the immediate direction of daily maritime operations, emergency response and recovery, supervision and enforcement of rules and regulations governing the navigation of the Canal, approval of new construction compliance with chocks and bits, boarding facilities, wheelhouse design features and visibility requirements, and for ensuring that vessels arriving for transit are properly equipped. Additionally, the unit is responsible for matters involving the safety aspects of vessel traffic flow and control, vessel material conditions and inspections, hazardous cargo, Canal physical conditions, and emergency response for fires or oil/chemical spills. The responsibilities of the Transit Operations Division executive manager are exercised through the Canal port captain on duty.

b. The *Marine Traffic Control Unit* (272-4201, fax: 272-3976, ETA@pancanal.com), headed by the Traffic Management Unit manager, is responsible for processing ETA information, preparation of the daily transit schedule, monitoring and coordinating all vessel movements within Canal operating areas, and administering the Panama Canal Transit Booking System.

c. The *Admeasurement and Billing Unit* (272-4567, fax: 272-5514, OPTC-A@Pancanal.com), headed by the Admeasurement Unit manager, is responsible for ascertaining the correct Panama Canal tonnage of vessels transiting the Canal, ascertaining and auditing the Total TEU Allowance (TTA) on full container vessels and Number of TEUs Transported (NTT) on other vessels with on deck carrying capacity, boarding and clearing of vessels for medical surveillance, general ship inspections, gathering information for the Ship Data Bank, and generating billing invoices for transits and related services.

d. The *Board of Inspectors* (272-3403, fax: 272-3548), headed by the Board of Inspectors chairman, is responsible for the official inquiry and examination into the circumstances surrounding marine accidents which occur in the Canal operating area, harbors, anchorages and adjacent areas involving Authority personnel and/or equipment. In addition, this office is responsible for the certification of marine credentials of Authority employees.

Vessel transits are a joint effort. In addition to the responsibilities outlined above, vessel owners, operators, agents, officers and crews are responsible for compliance with Canal rules and regulations. Cooperation of all concerned parties is necessary to ensure a safe and efficient transit.

4. Communication Channels

Direct communication with the Operations Department units may be established by the following means:

- a. MAIL: AUTORIDAD DEL CANAL DE PANAMÁ (ACP)
 (Name, position and title)
 ACP-OP
 P.O. Box 526725
 Miami FL 33152-6725
- b. FACSIMILE: (Name of Unit)
 (Fax numbers listed on the previous page.)
- c. TELEPHONE:(Telephone numbers listed on the previous page.)
- d. INTERNATIONAL COUNTRY CODE – For fax and telephone: 507
- e. TRAFFIC MANAGEMENT UNIT – Via e-mail: ETA@pancanal.com
- f. RADIO PRATIQUE MESSAGES – Via e-mail: optc-arp@pancanal.com
- g. DRAWING SUBMITALS – Via e-mail: opts-an@pancanal.com, or in compact disk, diskette or printed form directly to:

Courier mail: AUTORIDAD DEL CANAL DE PANAMA
 División de Operaciones de Tránsito (OPTS)
 Edificio 910, La Boca
 Balboa, Panamá
 República de Panamá
 (Telephones: 272-4191/4296)

Regular mail: AUTORIDAD DEL CANAL DE PANAMA
 División de Operaciones de Tránsito (OPTS)
 Balboa, Panamá
 República de Panamá

The drawings submitted via e-mail, disk or diskette should be saved preferably in PDF or TIFF file format, or in a file format compatible with AUTOCAD. All drawing and letter files are to be compressed together into one zip file using the WinZip file compression software.

5. Relevant Information for Canal Customers

a. Minimum Visibility and Other Transit Requirements

Vessels transiting the Panama Canal must comply with the minimum visibility requirements for the navigation bridge established in the Maritime Regulations for the Operation of the Panama Canal and in this Notice to Shipping.

Vessels that fail to comply with the minimum visibility requirements due to cargo, cargo gear, structures, or for any other reason, must inform the ACP of their visibility condition at least 48 hours prior to arrival in order to be properly scheduled and to minimize transit delays.

Vessels over 150 feet LOA are required to report their blind distance (in ship lengths), calculated for tropical fresh water, from conning positions 1, 2, and 3. Vessels 150 feet LOA or less must have a forward visibility that allows navigation ranges and aids to navigation to be visible from all navigation bridge conning positions. Container vessels are still required to provide their "EXCEED ACP VISIBILITY" condition at least 48 hours prior to arrival, in addition their blind distance.

The following information must be submitted at least 48 hours prior to arrival:

(1) Blind distance¹ in ship lengths at conning positions 1, 2 and 3, calculated for tropical fresh water;

(2) Operational status of port and starboard anchors;

(3) Operational status of gyro compass;

(4) Operational status of radar(s);

(5) Operational status of windshield wipers;

(6) Operational status of vessel's wheelhouse and bridge wing RPM, RAI, and pitch indicators and whether they are properly illuminated;

(7) Operational status of vessel's bridge wing whistle controls and whether they are located within 5 feet of the end of the bridge wings; and

¹ The "Blind Distance" is the forward distance from the bow of the vessel to the closest point on the water's surface which can be seen from all conning positions in the navigation bridge. An observer's height of eye of 1.80 meters above the bridge deck must be used to determine this distance, and must be reported in ship lengths. The Blind Distance at conning position #1 is not applicable to vessels with centerline cranes. All vessels arriving for transit must be ready to provide ACP boarding officers their Blind Distance calculated for tropical fresh water at conning positions 1, 2 and 3.

(8) Structure(s) on deck that may be obstructing or obscuring forward visibility.

The *Pre-arrival Vessel's Information–Visibility Requirements* form is available at <http://www.pancanal.com/eng/maritime/forms.html>.

Vessels arriving for transit without previously submitting the required information will be considered in compliance and will be scheduled accordingly; however, should deficiencies be detected upon arrival, the vessel may be subject to transit delays, as well as additional charges. The ACP will determine the conditions under which non-compliant vessels may be allowed to transit. Vessels that require additional resources, due to their visibility condition or other deficiencies, will be assessed the corresponding charges.

Full container vessels that fail to meet the ACP's minimum visibility requirements (1.0 ship length if laden or 1.5 ship lengths if in ballast) will continue to be assessed ACP Official Tariffs item number 1060.5100 or 1060.5110, depending on advanced notification of its condition.

b. H1N1 Pandemic Flu Virus

Radio pratique may be granted to vessels that declare no sickness or flu-like symptoms on board, even if the vessel has visited ports with known cases of H1N1 flu prior to arrival.

Vessels are still required to declare animal information and any diseases on board, as well as their last ten port calls. Vessels shall also declare in the "*Visit Remarks*" section of the EDCS *Ship Due* form whether any of the declared port calls are located in countries identified by the World Health Organization as having outbreaks of the H1N1 pandemic flu. Vessels must also declare whether passengers or crewmembers on board are experiencing flu-like symptoms, such as high fever, cough, fatigue, severe headache, vomiting, or lack of appetite, and the evolution of these symptoms.

Declaring the above information prior to arriving at Panama Canal waters is imperative in order to apply appropriate preventive measures to counter any possible spreading of this virus. Vessels reporting any of the above conditions may be subject to health measures that include, but are not limited to, sanitary and health authorities boarding the vessel to verify what has been declared.

c. New Panamax Vessels

There have been several recent inquiries from the shipping community regarding the vessel size that the expanded Panama Canal will be able to handle upon completion of the works in 2014. When the expansion is completed, the navigational channels will allow the transit of present post-Panamax containerships; *Suezmax* liquid-bulk tankers; *Capesize* dry-bulk carriers; and larger sizes of liquefied natural gas carriers, passenger ships and other vessel types within the established dimensional limits identified above.

The corresponding maximum dimensions for vessels that will transit these locks are 366 meters LOA, 49 meters in beam and 15.2 meters in tropical freshwater (TFW) draft. These dimensions are being used to define the **New Panamax** size vessel.

Details on the Panama Canal Expansion Program are available on the Panama Canal website at www.pancanal.com. In addition, those requiring technical assistance with vessel dimensions and appurtenances may contact OPT@pancanal.com.

d. ACP Maritime Regulations Book

An updated copy of the Maritime Regulations for the Operation of the Panama Canal must be maintained on board all transiting vessels. Each transiting vessel is entitled to a complimentary copy of said regulations and requests for these copies must be made in writing to the Transit Operations Division Admeasurement Unit, listing the name(s) of the vessel(s). Additional copies for the same vessel, albeit under another agent or owner, are available for purchase through the vessel's agent or directly from the Admeasurement Unit at a cost of \$10.00 USD each.

The payment must be made to the Citibank in Balboa or Cristobal using the "Speed Collect" deposit slip completed in the following manner:

Beneficiary:	Panama Canal Authority (ACP)
Account Number:	0-550305-054
Reference:	60.600002.400999
Depositor:	Individual or organization making the deposit
Blank area:	ACP Maritime Regulations

A copy of the deposit slip should then be taken to the Admeasurement Unit to obtain the Regulations. The Admeasurement Unit has offices located at Building 729, 1st floor, Balboa, or Building 1000, Port Captain's Office in Cristobal, and may be contacted by e-mail at OPTC-A@pancanal.com or at (507) 272-4567 (Balboa) or (507) 443-2298 (Cristobal).

e. Customer Comments Regarding ACP Services

In an effort to enhance the quality of service to our customers, we have improved our customer services process to better manage complaints, recommendations or recognitions regarding the services granted by the ACP. Effective from the date of issue of this Notice, please send comments regarding our services to:

Contact: Manuel E. Benítez
Title: Executive Vice President of Operations
E-mail: op@pancanal.com
Telephone: (507) 272-4500
Fax: (507) 272-3892
Mail: AUTORIDAD DEL CANAL DE PANAMA (ACP)
Operations Department
Bldg. 729
Balboa-Ancon, Panama

Contact: Yadira I. Sowley
Title: Claims Coordinator
E-mail: opxr-c@pancanal.com
Telephone: (507) 272-4990 or 272-4500
Fax: AUTORIDAD DEL CANAL DE PANAMA (ACP)
Operations Department
Bldg. 729
Balboa-Ancon, Panama

ORIGINAL SIGNED

Manuel E. Benítez
Executive Vice President of Operations

VESSEL REQUIREMENTS

Table of Contents

	PAGE
1. Definitions	1
a. Barge	1
b. Commercial Vessel.....	1
c. Passenger Vessel.....	1
d. Full Container Vessel	1
e. TEU	1
f. Dangerous Cargo	1
g. Articulated Tug-Barge Combination.....	1
h. Articulated Tug-Tank Combination	1
i. Maximum Authorized Transit Draft	1
j. Maximum Authorized Draft	1
k. Minimum Full Ahead Speed.....	1
l. Maximum Beam.....	2
m. Maximum Length	2
n. Maximum Width.....	2
o. Non-Self-Propelled Vessel.....	2
p. Protrusion	2
q. Published TFW Maximum Draft.....	2
r. Tropical Fresh Water (TFW).....	2
s. PC/UMS	2
t. Maximum Allowable Start Time	2
2. Size and Draft Limitations of Vessels	2
a. Maximum Length	2
b. Maximum Beam.....	3
c. Maximum Width.....	3
d. Protrusions	4
e. Maximum Height.....	4
f. Draft.....	4
g. Potential Seasonal Draft Restrictions	6
h. Release from Liability	8
i. Approval of Plans	12
j. Denial of Transit	14
k. Vessel Should Be Able to Relay at the Locks.....	14
3. Requirement for Pilot Platforms and Shelters on Certain Vessels	15
4. Navigation Bridge Features Required of Transiting Vessels	18
a. Authority	18

b. Wheelhouse	18
c. Bridge Wings.....	18
d. Normal Conning Positions.....	18
e. Panama Canal Minimum Visibility Requirements.....	19
f. Indicators.....	21
g. Very High Frequency (VHF) Radio.....	22
h. Whistle Controls	22
i. Steering Light.....	22
j. Bow/Stern Thrusters	23
k. Compass.....	23
l. Course Recorders	24
m. Bridge Wing Spotlights.....	24
n. Radar	24
o. Main Propulsion System	25
p. Use of Automatic Identification System (AIS).....	25
q. Steering gear.....	26
5. Requirements for Non-Self-Propelled Vessels	27
6 Vessels Requiring Towing Services	29
7. Deckload Cargo	29
8 Construction, Number and Location of Chocks and Bitts	31
9. Mooring Lines, Anchors and Deck Machinery	35
10. Boarding Facilities	35
11. Tug Assistance to Single-Hull Tankers	42
12. Admeasurement System for Full Container Vessels	43
13. Deck-Loaded Containers on Ships not Built for Container Carriage	44
a. General	44
b. Approval for Transits	44
c. Advance Notice and Inspection.....	45
d. Calculations of PC/UMS for Vessels not Designed to Carry Containers on Deck.....	45
14. Unauthorized Modification to the PC/UMS Net Tonnage Certificate	46
15. Calculation of PC/UMS Net Tonnage on Passenger Vessels	46
16. Dangerous Cargo Requirements	47
a. General	47
b. Test of Equipment on Board.....	47
c. Holding Due to Non-Compliance	47

d. Tankers Claiming Cargo Tanks as “Gas Free” or “Inert”	47
e. Reporting Dangerous Cargoes in Bulk	48
f. Reporting Shipments of Direct Reduced Iron	48
g. Precautionary Measures Due to Dangerous Cargo	49
h. Reporting Shipments of Hazardous Wastes	50
i. Reporting Radioactive Cargoes.....	50
j. Coverage Requirements for Transiting Vessels Carrying Radioactive Cargoes.....	51
k. Advance Notification of Shipments of Fissionable Materials.....	52
<u>17. Implementation of Annex II to MARPOL and Revised IBC Code</u>	<u>52</u>
<u>18. Pre-Arrival Cargo Declarations, Security Inspection and Escort</u>	<u>53</u>
<u>19. Hot Work Performed On Board Vessels</u>	<u>55</u>
<u>20. Manning Requirements</u>	<u>57</u>
<u>21. Additional Pilots Due to Vessel Deficiencies</u>	<u>57</u>
<u>22. Main Source of Electrical Power</u>	<u>58</u>
<u>23. Emergency Source of Electrical Power</u>	<u>59</u>
<u>24. Sanitary Facilities and Sewage Handling</u>	<u>59</u>
<u>25. Discharging of Vessel Wastes, Oily Bilge Water and Ballast Water</u>	<u>60</u>
<u>26. Emergency Escape Breathing Devices</u>	<u>60</u>
<u>27. Smoking Prohibition in Canal Waters</u>	<u>61</u>
<u>28. Proper Display of the Panamanian Flag</u>	<u>61</u>
<u>ANNEX 1 – Embarking or Disembarking During Transit</u>	<u>63</u>
<u>ANNEX 2 – All Locks Composite Maximum Clearances</u>	<u>65</u>

VESSEL REQUIREMENTS

1. Definitions

a. Barge: A flat-bottomed vessel of full body and heavy construction without installed means of propulsion.

b. Commercial Vessel: A self-propelled vessel other than a naval, military or other public vessel.

c. Passenger Vessel: A vessel that principally transports passengers and runs on fixed published schedules. All the spaces that have been identified and certified for the use or possible use of passengers are to be included in the total volume calculation of the vessel.

d. Full Container Vessel: Merchant ship built to carry large containers of standard size packed with cargo.

e. TEU: International measure standard for a container (20-foot equivalent unit), which is 20' x 8' x 8.5'.

f. Dangerous Cargo: Any material which is explosive, flammable, radioactive or toxic to humans or the environment.

g. Articulated Tug-Barge Combination: A pushing vessel and a non-tank barge pushed ahead rigidly connected to each other to form a composite unit. A composite unit means a pushing vessel rigidly connected by "mechanical means" to a barge being pushed so they react to the sea and swell as one vessel and as such considered a single power-driven vessel. "Mechanical means" does not include lines, hawsers, wires or chains. To be considered an ITB at the Panama Canal, such vessels must meet all current ACP regulations and requirements for transit and be able to operate in all conditions under which a ship of equivalent size can operate.

h. Articulated Tug-Tank Combination: A pushing vessel and a tank barge pushed ahead rigidly connected to each other to form a composite unit. The composite unit must meet all specifications and requirements set forth for an Integrated Tug-Barge Combination.

i. Maximum Authorized Transit Draft: Deepest point of immersion in TFW of a particular vessel permitted at anytime, Gatun Lake level and Canal restrictions permitting.

j. Maximum Authorized Draft: Lesser of the maximum authorized transit draft or the maximum tropical freshwater draft by Load Line Certificate.

k. Minimum Full Ahead Speed: The ACP has determined that the minimum *full ahead* speed required in order to complete transit in standard times is 8 knots.

l. *Maximum Beam:* The maximum breadth (width) of the hull between the outside surfaces of the shell plating.

m. *Maximum Length:* The distance between the forward and after extremities of a vessel, including the bulbous bow and protrusions (also length over-all - L.O.A.)

n. *Maximum Width:* The extreme width of a vessel, including protrusions, at its widest point.

o. *Non-Self-Propelled Vessel:* A vessel which either does not have installed means of propulsion, or has installed means of propulsion which does not function during transit. Also referred to as dead tow.

p. *Protrusion:* Anything that extends beyond any portion of the hull of a vessel, whether it is permanent or temporary, except for the main anchors.

q. *Published TFW Maximum Draft:* Deepest point of immersion in Gatun Lake waters as promulgated by the Executive Vice President of Operations, taking into account the water level of Gatun Lake and other limitations deemed necessary because of restrictions in the Canal.

r. *Tropical Fresh Water (TFW):* Tropical Fresh Water of Gatun Lake, density 0.9954 gms/cc at 85°F (29.4°C). [Transition to fresh water frequently alters the trim of large vessels 3 to 4 inches (7.5 to 10 centimeters) by the head.]

s. *Maximum Allowable Response Time:* The maximum allowable amount of time that it takes the main propulsion to respond from stop to ahead or from stop to astern, after a telegraph order is received, which must be tested before the transit begins.

t. *Panama Canal Universal Measurement System (PC/UMS):* The system based on the Universal Measurement System, 1969, using its parameters for determining the total volume of a vessel with the additional variations established by the Panama Canal Authority.

2. Size and Draft Limitations of Vessels

a. *Maximum Length*

(1) The maximum length overall including bulbous bow for commercial or non-commercial vessels acceptable for regular transit is 950 feet (289.6 m), except passenger and container ships which may be 965 feet (294.13 m) in overall length. Vessels transiting the Canal for the first time at an overall length exceeding 900 feet (274.32 m), whether newly-constructed or newly-modified are subject to the requirement of inspection and prior review and approval of vessel plans. Vessels not receiving advance approval and/or not complying with Canal requirements may be denied transit.

(2) The maximum length for integrated tug-barge combination acceptable for regular transit is 900 feet (274.32 m) overall including the tug. A tug-barge combination must transit together as one unit with the tug supplying the propelling power.

(3) The maximum aggregate overall length for non-self-propelled vessels acceptable for transit is 850 feet (259.1 m), including accompanying tugs. Accompanying tugs must lock through with the non-self-propelled vessel. One-time only transits that exceed these limitations may be permitted on a case-by-case basis with prior approval of the Transit Operations Division Executive Manager, and subject to requirements listed in paragraph 2.j (9) of this Section.

b. *Maximum Beam*

(1) The maximum beam for commercial or non-commercial vessels and the integrated tug-barge combination acceptable for regular transit measured at the outer surface of the shell plate is 106 feet (32.31 m).

(2) Wider commercial vessels including integrated tug-barge combination up to a beam of 107 feet (32.61 m) may be permitted, with prior approval of the Transit Operations Division Executive Manager, or his designee, to transit on a one-time delivery basis only if the deepest point of immersion does not exceed 37 feet (11.3 m), TFW.

(3) The maximum beam for non-self-propelled vessels (other than integrated tug-barge combinations) acceptable for transit is 100 feet (30.5 m). One-time transit of wider vessels may be permitted with prior approval of the Transit Operations Division Executive Manager, and subject to requirements listed in paragraph 2.j (9) of this Notice.

c. *Maximum Width*

(1) Vessels with a maximum width exceeding its maximum beam may not transit the Canal without prior review and approval of vessel plans. Vessels not receiving advance approval and/or not complying with Canal requirements may be denied transit.

(2) Vessels that carry cargo within 1 inch (2.5 centimeters) or less of the extreme beam must have approved provisions, such as rubbing bands; to protect the cargo should the vessel rest alongside the wall while in the chamber. The maximum beam of 106 feet (32.31 m) should not be exceeded by the cargo protection method. This is brought about by the large number of container vessels that are designed to load containers virtually to the extreme beam. If the ship lands on the wall in a heeled condition or where the locks wall fendering or miter gate fendering protrudes, damage may occur.

d. Protrusions

(1) Anything which extends beyond a vessel's hull, except for the main anchors, shall be considered a protrusion and subject to all applicable laws and limitations.

(2) The Authority is not responsible for damages to protrusions whether permanent or temporary.

(3) Vessels with protrusions may be permitted to transit provided that such protrusions will not interfere with the safe transit of the vessel or present a hazard to Canal structures, as determined by the Transit Operations Division Executive Manager. In either case, before transit is permitted, masters of vessels will be required to execute a form undertaking to release the Authority from liability in case of accident and to indemnify the Authority for damages sustained to or as a result of protrusions.

(4) Vessels with permanent protrusions must, prior to proceeding to the Canal, furnish detailed information about the protrusion(s), including plans and request authorization for transit. Advance information will minimize the possibility that transit may be delayed or denied. For detailed information, contact the Transit Operations Division Executive Manager.

(5) Vessels with protrusions extending beyond the maximum length and beam limitations specified in paragraphs 2.a and 2.b of this Notice, may, on a case-by-case basis, be permitted to transit, provided that approval is obtained in advance from the Transit Operations Division Executive Manager and that protrusions do not present a hazard or interfere with lock structures, equipment and/or operation, and the master executes a form releasing the Authority from liability. (See paragraph 2.h).

e. Maximum Height

The allowable height for any vessel transiting the Canal or entering the Port of Balboa at any state of the tide is 190 feet (57.91 m) measured from the waterline to its highest point. With prior permission from the Transit Operations Division Executive Manager, height may be permitted to 205 feet (62.5 m) on a case-by-case basis, with passage at low water (MLWS) at Balboa. Maximum Height Restrictions are due to the tide and the unpredictable upward movement of water from swells, surges, waves, etc., and maintenance equipment suspended beneath the bridge at Balboa.

f. Draft

(1) The maximum permissible draft for Canal transits has been set at 39 feet 6 inches (12.04 m) Tropical Fresh Water (TFW) at a Gatun Lake level of 81 feet 6 inches (24.84 m) or higher. [Gatun Lake density is 0.9954 gms/cc at 85°F (29.4°C).] This provides a safe navigational margin of at least 5 feet (1.52 m) over critical elevations in the Canal proper, and a clearance over the south sill of Pedro Miguel Locks of 1 foot 8 inches (0.50 m) at a Miraflores Lake Level of 54 feet 6 inches (16.61 m).

(2) Prior to the initial transit of a vessel whose transit draft will exceed 35 feet 6 inches (10.82 m), owners, operators or agents must supply in full the information required in the Regulation on Navigation in Panama Canal Waters (*ACP Navigation Regulations, Article 52*), and request the maximum authorized transit draft for the vessel (deepest point of immersion TFW) from the Transit Operations Division Executive Manager, not later than two weeks prior to the loading of the vessel. This request will be returned with the approved maximum authorized transit draft stamped thereon.

(3) The initial transit is permitted at or under the approved maximum authorized transit draft. After the initial transit, unless the vessel's agent or owner is notified of any restrictions imposed by the Canal Authority, this maximum authorized transit draft will remain in effect.

(4) All vessels transiting the Canal should have sufficient ballast to permit safe handling during transit.

(5) A vessel whose ballast draft does not meet the minimum draft requirements established by this section may be accepted for transit on a regular basis, provided the vessel operator is granted permission after submitting the following information to the Transit Operations Division Executive Manager:

- (a) Principal dimensions of the vessel.
- (b) Deepest attainable minimum draft (fore and aft).
- (c) Limitations on visibility fore and aft from the navigation bridge.

(d) Necessary excerpts from the vessel's plans, drawings and maneuvering data that relate to the vessel's suitability for transit. The information submitted should include the proposed Panama Canal ballast condition detailed output, showing the status of all ballast and consumable tanks, plus the maneuvering data in accordance with IMO Resolution A.601 (15), Appendices 1, 2 and 3.

(6) Table I provides the minimum saltwater drafts for vessels anticipating transit. Drag must not adversely affect maneuverability. Any drag beyond 6 ft (1.83 m) is considered adverse drag in the Panama Canal and adjacent waters.

LENGTH	MINIMUM DRAFTS
Up to 425' (129.54 m)	Trimmed so pilot can see the ranges over the forecastle from center of navigation bridge
Over 425' (129.54 m)	8' (2.44 m) forward, 14' (4.3 m) aft, TSW
Over 475' (144.8 m)	18' (5.5 m) forward, 20' (6.1 m) aft, TSW
Over 525' (160.02 m)	20' (6.1 m) forward, 22' (6.71 m) aft, TSW
Over 580' (176.8 m)	22' (6.71 m) forward, 24' (7.32 m) aft, TSW
Over 625' (190.5 m)	24' (7.32 m) forward, 26' (7.93 m) aft, TSW

Table I - Minimum Salt Water Drafts

(7) **Figure 1** provides the limiting drafts due to bilge radius. On an off-center lockage with the vessel touching the lock wall, the turn of the bilge will clear the locks wall batters at the most critical point as shown in the table.

(8) A vessel having received permission to transit at less than the minimum required draft will be inspected by the Authority upon its first visit under ballast conditions. If the vessel is acceptable for transit at less than the prescribed minimum draft, the operator will be notified that transit on a regular basis is authorized provided the vessel meets the special minimum draft specified in that notification and that the master signs a form releasing the Authority from liability.

(9) If the vessel is found not to be acceptable for transit on a regular basis, a single transit may be authorized, at the discretion of the Transit Operations Division Executive Manager, subject to imposition of special conditions that may be required for reasons of safety or continuance of regular Canal operations.

(10) Vessels are expected to arrive at the Canal properly trimmed and with a draft which, when in fresh water, its deepest point of immersion will not exceed either the published TFW Draft, the Maximum Authorized Transit Draft established by the Canal for that particular vessel, or the maximum allowable draft as a mean established by the classification society, whichever is less.

(11) Vessels with drafts exceeding these figures, when in Miraflores Lake, are subject to denial of transit. Northbound vessels found by actual reading to be overdraft would be required to turn around and proceed back to sea, and the transit would be considered completed. Southbound vessels will be held in the Gatun Anchorage. The transit will be reinitiated only after the Transit Operations Division Executive Manager, considers that it is safe to proceed.

(12) Masters of vessels are reminded that personnel from transiting vessels are not permitted to climb or hang over the side of the vessel from ladders or boatswain's chairs while the vessel is in the lock chamber. Personnel are prohibited from disembarking onto the lock walls at any time for any purpose, except as allowed in Section 2.31 of the Operations Department Operations Manual (Embarking or Disembarking during Transit, which appears in Annex 1 to this Notice to Shipping). Draft readings are obtained from locks personnel through the pilot.

g. *Potential Seasonal Draft Restrictions*

(1) In the event of an unusually dry season (nominally, 1 out of 10 years) draft restrictions might become necessary.

(2) During the rainy season (from May to December), Gatun Lake and Madden Lake, the upstream reservoir for the Canal and the municipal water supply of Panama City, are filled to capacity. During the dry season (from December to May), the Madden Lake reserve is drawn off to keep Gatun Lake at an optimum level. In an unusually dry season, the Madden Lake reserve is exhausted and the Gatun Lake level continues to decrease. As the Gatun Lake level is depleted

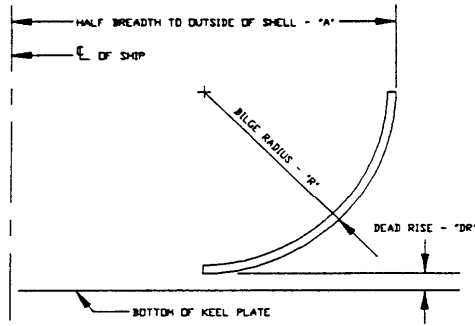

	Radius of turn of bilge (meters)				
	0.30	0.60	0.90	1.20	1.50
0.000	10.87	11.12	11.37	11.62	11.87
0.025	10.89	11.14	11.39	11.64	11.89
0.050	10.91	11.16	11.41	11.66	11.91
0.075	10.93	11.18	11.43	11.68	11.93
0.100	10.95	11.20	11.45	11.70	11.96
0.125	10.97	11.22	11.47	11.73	11.98
0.150	10.99	11.24	11.50	11.75	12.00
0.175	11.01	11.27	11.52	11.77	12.02
0.200	11.04	11.29	11.54	11.79	12.04
0.225	11.06	11.31	11.56	11.81	
0.250	11.08	11.33	11.58	11.83	
0.275	11.10	11.35	11.60	11.85	

	Radius of turn of bilge (feet)				
	1'	2'	3'	4'	5'
0'	35'8"	36'6"	37'4"	38'2"	39'0"
1"	35'9"	36'7"	37'5"	38'3"	39'1"
2"	35'10"	36'8"	37'6"	38'4"	39'2"
3"	35'10"	36'8"	37'6"	38'5"	39'3"
4"	35'11"	36'9"	37'7"	38'5"	39'3"
5"	36'0"	36'10"	37'8"	38'6"	39'4"
6"	36'1"	36'11"	37'9"	38'7"	39'5"
7"	36'2"	37'0"	37'10"	38'8"	39'6"
8"	36'3"	37'1"	37'11"	38'10"	
9"	36'3"	37'1"	38'0"	38'10"	
10"	36'4"	37'2"	38'0"	38'10"	
11"	36'5"	37'3"	38'1"	38'11"	

Example: To find draft of ship having a radius-of-turn-of-bilge of 1.325 m., read across top of table to column headed 1.20 m. thence down column opposite 0.125 m. Read 11.73 m.

Notes: a) Dead rise not included in above tabulations and must be added to above readings.
 b) Allows for 15-cm. thick rubber fenders on lock walls at batter locations

Example: To find draft of ship having a radius-of-turn-of-bilge of 4'4", read across top of table to column headed 4' thence down column opposite 4" - Read 38'5".

Notes: a) Dead rise not included in above tabulations and must be added to above readings.
 b) Allows for 6-inch thick rubber fenders on lock walls at batter locations.

FIGURE 1 - Limiting Drafts Due to Bilge Radius Contacting Chamber Batters

below 81.5 feet (24.84 m), it becomes necessary to reduce the maximum allowable draft to preserve the safe navigation margin. The reductions are made in 6-inch (15.24 cm) decrements, with three-week advance notice when possible, based on computer-assisted lake level and precipitation forecasts made by the Authority's hydrologists and meteorologists. Ships already loaded to a prevailing draft limitation at the time of promulgation of a new draft restriction are waived for transit, subject to overriding safety considerations. Ships loading after promulgation of a new draft restriction are held to a tolerance of not more than 6 inches (15.24 cm) above that restriction and may be required to trim or off-load the ship to achieve a safe transit draft.

h. Release from Liability

(1) Masters of vessels will, prior to transit, be required to execute a form undertaking to release the Authority from liability in case of accident and to indemnify the Authority for damages sustained in the following instances:

(a) When a vessel transits at less than the minimum drafts established in paragraph 2.f, has a list in excess of three degrees, or is so loaded or trimmed that maneuverability is adversely affected.

(b) When a vessel has protrusions.

(c) When visibility from the vessel's navigation bridge presents a hazard, as determined by the Transit Operations Division Executive Manager. (See Section 4.)

(d) When the vessel's chocks, bitts or other equipment does not meet Canal requirements as determined by the Transit Operations Division Executive Manager. (See Section 8.)

(e) When a vessel transits on a one-time delivery basis with extreme beam exceeding 106 feet (32.31 m).

(2) Pilots or boarding officers are requested to have the master of the vessel sign Form 4323, "Undertaking to Release and Indemnify", prior to docking vessels in Balboa, Cristobal and Rodman Piers when such vessels are exceeding the allowable drafts shown in **Tables II, III and IV**, or when a vessel is to be berthed on a pier that has inadequate or absent fendering and/or lighting.

(3) A refusal to sign such release may result in a delay of transit.

DOCK	BERTH	USABLE LENGTH	DEPTH	MAXIMUM WATER DRAFT	MAXIMUM LENGTH OF SHIP	REMARKS
6	AB	742 ft 226.21 m	32' 08" 10.00 m	31' 08" 9.64 m	600 ft 182.92 m	F / M / L OIL / WATER / DRY & LIQUID BULK / PASSENGER / CAR CARRIER
7	ABCD	1,050 ft 320.12 m	AB:33' 01" 10.08 m CD:32' 06" 9.90 m	AB: 32' 01" 9.78 m CD: 31' 06" 9.60 m	850 ft 259.14 m	F / M / L OIL / WATER/ DRY & LIQUID BULK / PASSENGER / CAR CARRIER
8		470 ft 143.29 m	30' 02" 9.19 m	29' 02" 8.89 m	530 ft 161.59 m	DRY DOCK EXCLUSIVE USE
13		280 ft 85.37 m	20' 00" 6.10 m	19' 00" 5.80 m	220 ft 67.07 m	REPAIRS
14	AB	1,054 ft 321.22 m	42' 06" 13.00 m	41' 06" 12.70 m	954 ft 290.85 m	CARGO CONTAINER
15	AB	900 ft 274.39 m	42' 06" 13.00 m	41' 06" 12.70 m	800 ft 243.90 m	CARGO CONTAINER
16		1,100 ft 335.37 m	52' 05" 16.00 m	51' 06" 15.70 m	1,000 ft 304.88 m	CARGO CONTAINER
17		1,100 ft 335.37 m	52' 05" 16.00 m	51' 06" 15.70 m	1,000 ft 304.88 m	CARGO CONTAINER

TABLE II - Depths and Drafts in Balboa

Area No.	True Heading	Berth	Pier Length				Depth MLWS		Max. S W Draft MLWS		Maximum Length of Ship at Maximum Draft		Height Above Low Water (MLWS)	
			Total Pier Length		Usable Length		Feet	Meters	Feet	Meters	Feet	Meters	Feet	Meters
			Feet	Meters	Feet	Meters								
1		Approach to Pier 1					40'00"	12.19	39'00"	11.89				
2	232°	Pier 1 – North C	704	215	400	122	30'06"	9.29	29'06"	8.99	550	168	25' 4"	7.72
2	232°	Pier 1 – North D	704	215	562	171	30'06"	9.29	29'06"	8.99	712	217	25' 4"	7.72
3	232°	Pier 1 – South A & B	704	215	625	191	34'06"	10.51	33'06"	10.21	775	236	25' 4"	7.72
4-5	232°	Approach to Pier 2					35'00"	10.67	34'00"	10.36				
6	232°	Pier 2 – North C & D	704	215	630	192	29'06"	8.98	28'06"	8.68	775	230	25' 4"	7.72
7	232°	Pier 2 – South A	704	215	450	137	26'00"	7.91	25'00"	7.61	550	168	25' 4"	7.72
7	232°	Pier 2 – South B	704	215	650	198	26'00"	7.91	25'00"	7.61	750	229	25' 4"	7.72

TABLE III: Rodman Piers Draft Limitations

Notes:

1. ACP under keel clearance is 1 foot.
2. Tables II information provided by Panama Ports Company on June 17, 2007.
3. Table III information provided by Parque Industrial Marítimo de Panamá, S. A. on April 20, 2008.
4. Piers on Areas No. 2, 3, 6 and 7; has no beam limitations and can be use for loading or discharging fuel or stores.

DOCK	BERTH	USABLE LENGTH	DEPTH	MAXIMUM WATER DRAFT	MAXIMUM LENGTH OF SHIP	REMARKS
6	AB	1030 ft 313.94 m	41'00" 12.50 m	A: 40'00" 12.19 m B: 36'00" 10.97 m	970 ft 295.66 m	PASSENGERS / RO-RO CARGO
6	CD	1030 ft 313.94 m	41'00" 12.50 m	40'00" 12.19 m	1030 ft 313.94 m	PASSENGERS
6	E	240 ft 73.20m	41'00" 12.50 m	33'00" 10.06 m	240 ft 73.15 m	WATER
7	AB	977 ft 297.78 m	41'00" 12.50 m	A: 40'00" 12.19 m B: 39'00" 11.88 m	920 ft 280.42 m	F / M / L OIL / WATER ALL TYPE OF CARGO
7	CD	1000 ft 304.80 m	41'00" 12.50 m	C: 40'00" 12.19 m D: 37'00" 11.27 m	1000 ft 304.80 m	ALL TYPE OF CARGO
7	E	240 ft 73.15 m	41'00" 12.50 m	40'00" 12.19 m	240 ft 73.15 m	WATER
8	AB	990 ft 301.75 m	41'00" 12.50 m	A: 40'00" 12.19 m B: 36 ft 10.97 m	942 ft 287.12 m	F / M / L OIL / WATER ALL TYPE OF CARGO
8	CD	1010 ft 307.84 m	41'00" 12.50 m	C: 40'00" 12.19 m D: 38'00" 11.58 m	955 ft 291.08 m	WATER
8	E	250 ft 76.20 m	41'00" 12.50 m	40'00" 12.19 m	250 ft 76.20 m	WATER
9	AB	1068 ft 325.53 m	41'00" 12.50 m	A: 39'00" 11.88 m B: 37'00" 11.27 m	1036 ft 315.77 m	F / M / L OIL / WATER ALL TYPE OF CARGO
10		423 ft 128.93 m	41'00" 12.50 m	30'00" 9.14 m	600 ft 182.88 m	F / M / L OIL / WATER ALL TYPE OF CARGO
14		460 ft 140.20 m	35'00" 10.36 m	28'00" 8.53 m	500 ft 152.40 m	REPAIRS
15		900 ft 274.32 m	35'00" 8.84 m	29'00" 8.84 m	700 ft 213.36 m	REPAIRS
16	AB	1070 ft 326.13 m	41'00" 12.50 m	A: 39' 08" 12.08 m B: 39' 04" 11.98 m	1000 ft 304.80 m	F / M / L OIL / WATER DRY & LIQUID BULK
16	CD	1070 ft 326.13 m	41'00" 12.50 m	C: 40'00" 12.19 m D: 38'00" 11.58 m	1000 ft 304.80 m	F / M / L OIL / WATER DRY & LIQUID BULK
16	E	458 ft 139.60 m	41'00" 12.50 m	40'00" 12.19 m	300 ft 91.44 m	F / M / L OIL / WATER
MINDI		275 ft 83.83 m	29'00" 8.83 m	26'00" 7.92 m	300 ft 91.62 m	EXPLOSIVE CARGO

TABLE IV - Depths and Drafts in Cristobal

NOTE: Between Docks 6 CD – 7 AB, 7 CD – 8 AB and 8 CD – 9 there is a 105 ft beam restriction.

i. *Approval of Plans*

(1) The plans for new construction or modification for each vessel or class of vessels should be submitted to the Transit Operations Division for review prior to modification or construction. A minimum of two and a maximum of four sets of copies of each drawing should be submitted. The ACP will retain for its records and files a single set of the drawings submitted and will return only up to three sets of copies of the principal drawings submitted. Failure to comply with this requirement may result in delay or denial of transit because of unsuitable or unsafe arrangements.

(2) The numerous constraints affecting the transit schedules of vessels and tows make it important that information provided in advance of the initial transit include the following documents for approval (a minimum of two copies of each drawing must be submitted):

- General Arrangement (indicating deployed boarding facilities, blue steering light and pilot shelters/platforms)
- Mooring Arrangement (indicating chock/bitt sizes and maximum safe working load/strain capacities)
- Wheelhouse Arrangement (showing required aids to navigation, such as indicators, wipers, horn controls, radar and others)
- Visibility Calculations (indicating compliance with ACP visibility requirements of Paragraph 4.e of this Notice)
- Section Views showing the vessel inside the lock chamber pressed against both center and side walls, indicating clearances of protrusions from lock structures and equipment (for vessels with protrusions – the locks chamber drawing may be downloaded from the Panama Canal web page at http://www.pancanal.com/eng/maritime/notices/All_Locks_Composite_Maximum_Clearances_Limiting_Dimensions.pdf)

For reference, (one copy of each drawing retained for our records):

- Midship Section (or Shell Expansion and bilge radius information, if the Midship Section is not available)
- Engine room plans
- International Tonnage Certificate
- International Load Line Certificate
- Detailed drawings of chocks and bitts showing sizes and maximum strain capacities, if not indicated in the mooring arrangement.

This advance information will minimize the possibility that transit might be denied due to noncompliance with Canal regulations. For detailed information, contact the Transit Operations Division Canal Port Captain South Section Manager (OPTS).

(3) Vessels that have had the appropriate plans approved will normally retain such approval unless it is determined by the Transit Operations Division Executive Manager that modifications are necessary to ensure safe transit.

(4) The Transit Operations Division accepts electronic drawing submittals via e-mail or by regular mail in compact disk or diskette.

(5) The drawings are to be saved preferably in PDF or TIFF file format, or in a file format compatible with AUTOCAD. All drawing and letter files should be compressed together into one zip file.

(6) Upon review, the submittals will be stamped electronically and returned via e-mail. In this manner, the recipient has control of printing any number of copies of the stamped drawings needed to meet distribution requirements.

(7) Additionally, for the purpose of admeasurement, vessels transiting the Canal for the first time shall present an International Tonnage Certificate (69) (ITC 69) or a substitute document deemed acceptable by the Authority, based on a system substantially similar to the one adopted by the aforementioned agreement. These vessels shall provide plans, classification certificates and documents with information stating the Total Volume of the vessel or sufficient information to the Admeasurement and Billing Unit (OPTC-A) to determine this volume through mathematical calculations. Please refer to Agreement No.2, Article 5 of the "Maritime Regulations for the Operations of the Panama Canal", which may be downloaded from:

- <http://www.pancanal.com/eng/maritime/regulations/>
- <http://www.pancanal.com/eng/legal/reglamentos/acuerdo2-eng.pdf>.

There is no charge for ACP admeasurement calculations if the 'ITC 69' values submitted are confirmed. If 'ITC 69' values are not confirmed the vessel will have to be admeasured and the ACP will assess appropriate charges.

Prior to transit, one copy of the following drawings/documents are to be submitted to the Admeasurement and Billing Unit (OPTC-A) for reference and returned after Admeasurement calculations are completed:

- Lines Plan (or offsets table, if Lines not available)
- Midship Section (or Shell Expansion and bilge radius info, if Midship not available)
- General Arrangement
- Cargo Securing Manual (container section)
- Capacity Plan
- International Tonnage Certificate

- International Load Line Certificate
- Suez Tonnage Certificate (if it has one)

j. Denial of Transit

Any vessel may be denied passage through the Canal when the character or condition of the cargo, hull or machinery is such as to endanger Canal structures, or which might render the vessel liable to obstruct the waterway, or whose draft at any part of the vessel exceeds the maximum allowable draft as designated from time to time by the Canal Authority. Other specific circumstances under which a vessel shall be denied transit are:

- (1) When the vessel's maximum point of immersion exceeds its maximum authorized draft as determined by its bilge keel radius.
- (2) When the vessel's maximum point of immersion exceeds the published TFW maximum draft then in effect.
- (3) When the vessel's mean draft exceeds the maximum allowable mean draft as provided by the most current Load Line Certificate.
- (4) When the length overall, including bulbous bow, exceeds the length stated in Section 2.a of this Notice.
- (5) When the maximum width or extreme beam exceeds the width stated in Section 2.b of this Notice by any amount unless the vessel was approved for regular transit prior to March 10, 1981.
- (6) When a vessel has protrusions, which will interfere with the safe transit of the vessel or present a hazard to Canal structures as determined by the Transit Operations Division Executive Manager.
- (7) When the vessel has a list of ten degrees or more.
- (8) When visibility from the navigation bridge of a vessel does not meet minimum requirements as stated in Section 4.d and/or when in the judgment of the Transit Operations Division Executive Manager transit would present an extreme hazard.
- (9) Vessels whose list, trim or handling characteristics are such as to endanger themselves, ACP appurtenances and/or a third party, may have such further limitations placed on them as the Canal Authority deems necessary to insure reasonable safety.

k. Vessel Should Be Able to Relay at the Locks

Due to the increase in numbers and size of transiting vessels, relay lockage procedures have become the norm. This lockage procedure involves mooring to the lock wall inside the lock chamber; casting off all locks locomotives and receiving a different set of locks locomotives to continue the lockage. During this process, the affected vessel is subject to the vagaries of the wind and any associated lockage currents, and may contact the lock wall. Such contact may involve heeling of the vessel, which would bring the hull shell plating and any protrusions thereto, closer to the locomotives at the very time the locomotive must pass down the length of the vessel. Measures must be taken to ensure the safety of the vessel, locks equipment and their operators. To that end, all new vessels must maintain a

minimum clearance of 3.3 feet (one meter) between any locks equipment and any protrusions extending beyond the vertical plane of the hull shell plating at the waterline. Additionally, any vessel with windows, port lights, doors, side ports or other critical appurtenances below a level of 42.2 feet (12.9 m) above the waterline at transit draft must take measures to ensure its protection in case the vessel contacts the lock wall.

3. Requirement for Pilot Platforms and Shelters on Certain Vessels

a. As required by the *ACP Navigation Regulations, Article 64*, suitable platforms and shelters must be provided by certain vessels for assisting pilots. Based on current operating experience, the following vessels with a length of 900 feet (274.32 m) overall or more may require two or more pilots when transiting the locks of the Canal. Control pilots will position assisting pilots where they can best contribute to vessel control, which may be at any of the existing pilot platform locations:

(1) Vessels with the bridge in the extreme after part of the vessel (assisting pilot platforms will be forward).

(2) Vessels with the bridge in the extreme forepart of the vessel (assisting pilot platforms will be aft).

(3) This requirement also applies to container vessel with a length of 700 feet (213.36 m) overall or more.

b. Platforms must afford suitable shelter to protect assisting pilots from rain and sun. **Figure 2** is a sketch of a simplified pilot platform acceptable to the Authority.

c. Each platform is to be erected directly over the furthest point forward of the extreme beam at the waterline and not more than six inches inboard from the outside of the vertical plane of the shell plating. For vessels where the bridge is located forward, these pilot platform shelters will be required to be erected directly over that position which is the furthest point aft of the extreme beam at the waterline and not more than six inches inboard from the outside surface of the vertical plane of the shell plating.

d. In addition, all vessels whose extreme beam is 80 feet (24.38 m) or more are required to provide bridge wing shelter platforms for the protection of control pilots at Conning Positions No. 4 and 5. **Figure 3** is a sketch of a bridge wing shelter platform acceptable to the Authority. Alternate arrangements, including portable shelters, which provide equivalent or better protection and visibility, may be acceptable.

e. The awning indicated in the sketches in **Figures 2** and **3** of this section is to be made of suitable material to provide shelter from the sun and rain. The deck of pilot platforms shall be made of wood or other material with non-skid surface, sufficient to dry footing at all times. Overhead awning should be rigged to avoid spilling water inside the framework of the shelter during rain.

f. Further inquiries on this subject should be directed to the Transit Operations Division Executive Manager.

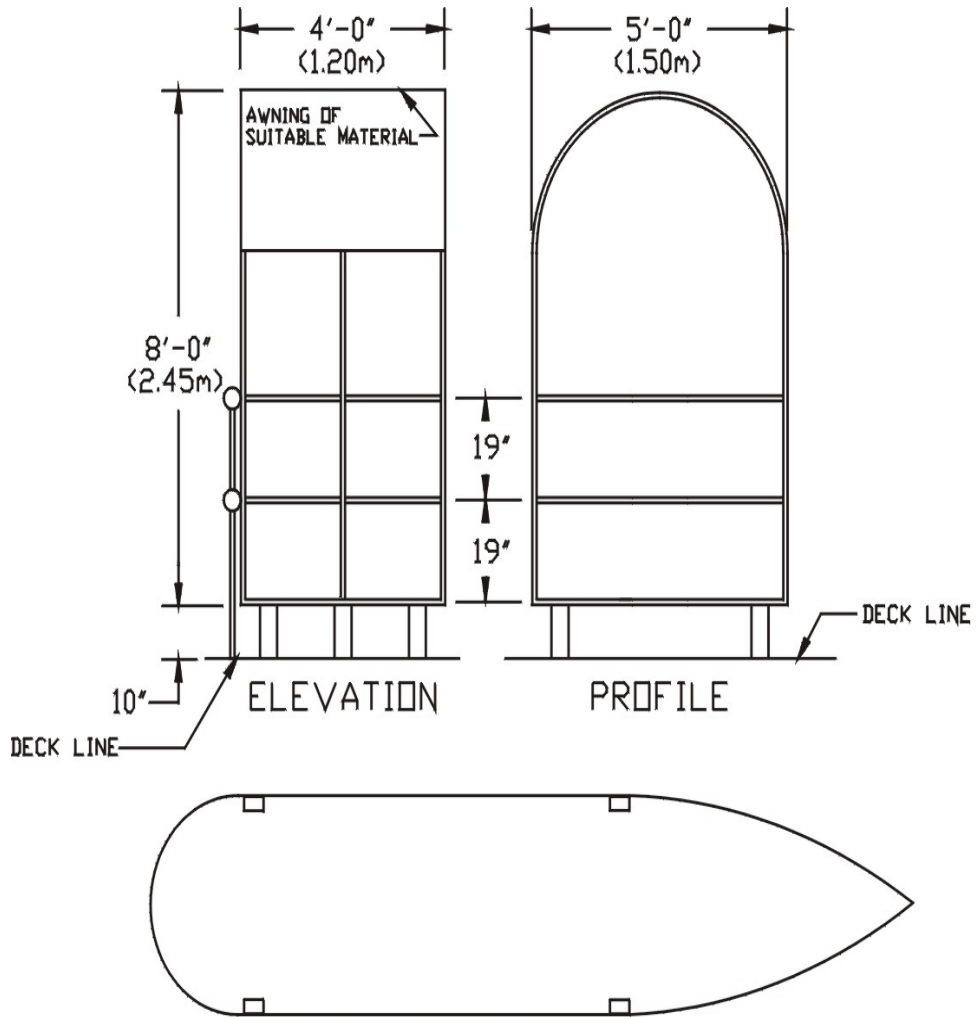

FIGURE 2 – Pilot Platforms and Shelters

Pilot platforms and shelters may be required on vessels with an overall length of 900 feet (274.32 m) or more and on container vessel with an overall length of 700 feet (213.36 m) or more.

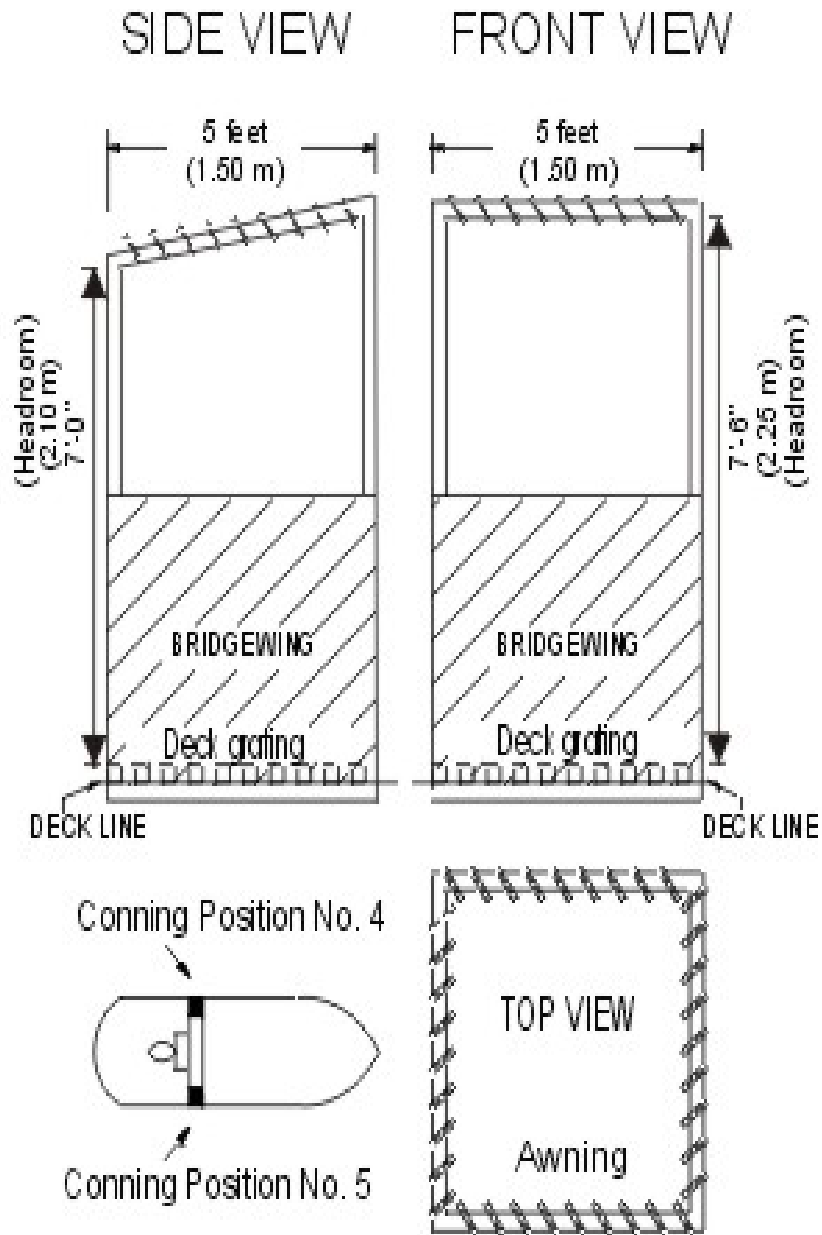

FIGURE 3 - Pilot Platforms and Shelters

4. Navigation Bridge Features Required of Transiting Vessels

a. Authority - The following vessel bridge design rules are issued under authority of the *ACP Navigation Regulations, Articles 29, 50, and 61 to 64*. Vessels not meeting the requirements of these rules after January 1, 1980, may, at the discretion of the Canal Authority, be allowed to transit after execution of an undertaking and release form. This undertaking and release form is to be made on behalf of the owners, operators, master and all other persons having an interest in the vessel and shall provide that in case of damage of any sort proximately resulting from non-compliance with these rules, the Canal will be released from any liability and will be indemnified for any damage or expense incurred.

b. Wheelhouse - Wheelhouse windows shall be:

- (1) Of sufficient size and number to provide a clear view.
- (2) Of clear safety glass. Tinted windows must be removable.
- (3) Arranged so as to include a center window.
- (4) Equipped with an efficient, mechanically, operated rain wiper blade on the window at the normal bridge Conning Position 1. In the case of vessels with a center crane or other type of obstruction, blade type wipers shall be located on the windows at normal bridge Conning Positions 2 and 3. In case of enclosed bridge wings, blade type wipers shall be located also on the forward and aft windows at Conning Positions 4 and 5.

c. Bridge Wings - Bridge wings (shall extend to the maximum beam of the vessel and shall provide a clear, unobstructed passage) (shall be provided with a clear, unobstructed passageway of at least 3.93 feet (1.2 m) wide) along their forward portions from the wheelhouse doors to the extreme ends of the bridge wings. If it is impossible to extend these bridge wings the full breadth of the vessel, they shall extend as far as possible and swing-out or portable platforms shall be provided as follows:

- (1) Extending to the maximum beam of the vessel.
- (2) Of adequate size, strength and rigidity to hold two persons.
- (3) Equipped with horizontal safety handrails and a toe board around the deck, 4-inches high minimum.
- (4) Platforms shall be safe and secure and maintained in good condition.

d. Normal Conning Positions (see Figure 4)

- (1) Conning Position 1 is located directly behind and close to the forward center wheelhouse window.
- (2) Conning Position 2 is located to port of Conning Position 1 directly behind and close to the nearest window thereto that provides a clear unobstructed view ahead.
- (3) Conning Position 3 is located to starboard of Conning Position 1, directly behind and close to the nearest window thereto that provides a clear unobstructed view ahead.
- (4) Conning Position 4 is located at the extreme end of the port bridge wing and must provide a clear and unobstructed view fore and aft of the vessel's port side.

(5) Conning Position 5 is located at the extreme end of the starboard bridge wing and must provide a clear and unobstructed view fore and aft of the vessel's starboard side.

(6) No equipment or instrumentation shall block the close approach to the forward windows at Conning Positions 1, 2 and 3 and from the forward to after portions of the bridge wing ends at Conning Positions 4 and 5. A minimum of 3.28 feet (1 m) clearance from consoles or obstructions should be provided in these areas. Special requests for relaxation of this requirement may be considered on a case-by-case basis. Inset navigation lights fitted on the bridge wing ends are unacceptable, as they block the pilot's close approach to these areas. Bridge wing controls shall be so positioned that neither the controls nor the operator interfere with the pilot's functions.

Note: *Vessels with enclosed bridge wings must provide a means for the pilot to have a clear and unobstructed view of the vessel sides as required by paragraphs 3.4.d (4) and (5) above. This may require an opening type window to be fitted on the outboard bulkhead of each bridge wing to allow the pilot to view the waterline all along the side of the vessel; or, when catwalks are fitted that extend to the maximum beam of the vessel, a 7 feet (2.134 m) high by 3 feet (0.915 m) wide door should be provided on the outboard bulkhead of each bridge wing in order to allow the pilot to step out onto the catwalk and look over the railing to view the waterline all along the side of the vessel.*

e. Panama Canal Minimum Visibility Requirements

(1) Vessels transiting the Panama Canal must comply with the following navigation bridge minimum visibility requirements:

(a) If the vessel is laden, the view of the water surface from any conning position in the navigation bridge shall not be obscured by more than one (1) ship length forward of the bow, under all conditions of draft and trim.

NOTE: *Vessels billed at the laden rate are considered laden for the purposes of this requirement.*

(b) If the vessel is in ballast (not laden), the view of the water surface from any conning position in the navigation bridge shall not be obscured by more than one and one-half (1.5) ship lengths forward of the bow, under all conditions of draft and trim.

(c) If the visibility from normal conning positions is obscured by cargo gear or other permanent obstructions forward of the beam, the total arc of obstructed visibility from Conning Position 1 shall not exceed 15 degrees.

(d) The side hull plating at the vessel's waterline, fore and aft, shall be visible from bridge wing conning positions.

(e) Vessels shall be required to execute an Undertaking and Release if visibility from the bridge is considered by the Canal Authority to present a hazard.

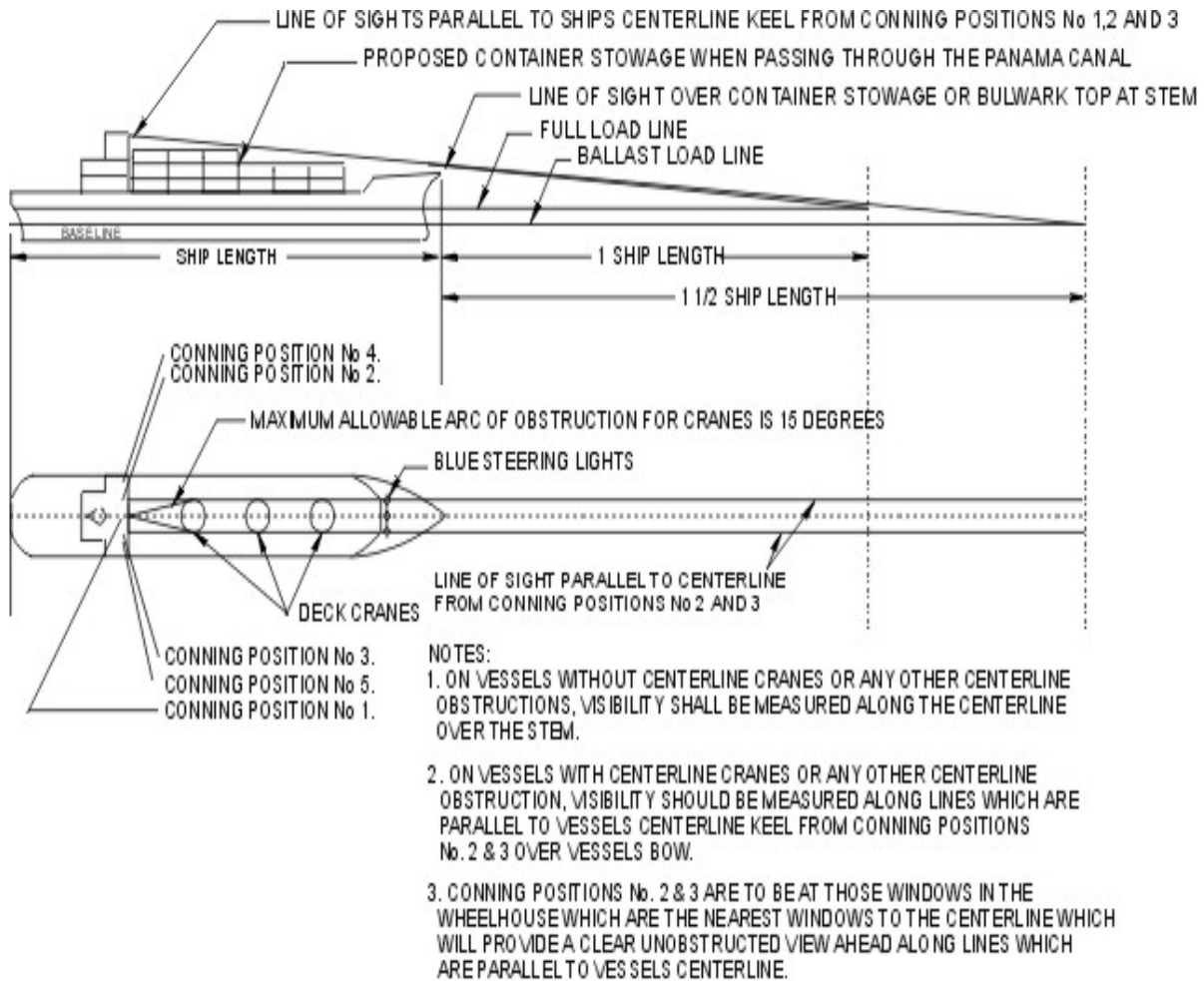

FIGURE 4 - Normal Conning Positions

(2) Under an ongoing test, which began January 30, 2000, container vessel may be allowed to transit while not in compliance with the visibility requirements in Subsection 4.e(1) above, provided they comply with all of the following requirements and conditions:

(a) Must be 700 feet (213.36m) or more in length.

(b) Must have clear visibility forward; therefore, should not be equipped with centerline cranes or cargo gear, which in any way obstruct forward visibility.

(c) The view of the water surface from conning position No.1 shall not be obscured by more than two (2) ship lengths, or 500 meters, whichever is less, forward of the bow to 10° on either side, under all conditions of draft, trim and deck cargo.

(d) Must have installed, prior to transit, the pilot shelter platforms as required in Article 64 of the “Maritime Regulations for the Operations of the Panama Canal.”

(e) Must be equipped with an operational bow thruster, otherwise it may, at pilot request, be assigned and charged for an additional tug through the Culebra Cut .

(f) Must notify the ACP of their voluntary request to “Exceed ACP Visibility.” This notification, which may be included in the remarks section of the ETA message, must be received at least 48 hours prior to arrival stating that they “Exceed ACP Visibility.”

(g) Incur a service charge in the amount of \$2,500 to cover the costs resulting from the assignment of additional resources provided adequate notification, as stated in paragraph f, has taken place. If notification is not received at least 48 hours prior to the vessel’s **arrival**, the service charge will be \$6,500.

(h) Vessels failing to meet ACP visibility requirements that nonetheless qualify for this test, but for which notification was not received as required in *paragraph (f)* above, may be subject to delays and additional charges as well as the \$6,500 service charge.

(i) Requests to modify previous ETA messages, which would change the “Exceed ACP Visibility” status of the vessel, will only be allowed, with no service charge assessed, if notification is received 48 hours prior to **arrival**.

(3) All vessels that arrive for transit not in compliance with the Panama Canal visibility requirements as outlined above are subject to the conditions outlined in paragraph 4.a of this Section, as well as the conditions and service charges stated in paragraph (g) on page 20. Any denial of transit or transit delays experienced due to non-compliance of the above or any other non-compliance will not be considered as an acceptable justification for claims from vessels for delays in navigation, in accordance with Article 6 of the “Maritime Regulations for the Operations of the Panama Canal.”

NOTE: *Vessel owners are encouraged to raise the height of the navigation bridge of their existing vessels and to have new vessels designed and built with higher navigation bridges so as to provide navigators the best possible visibility.*

f. Indicators - All vessels over 150 feet (45.72 m) in length shall be provided with:

(1) *Rudder angle indicators as follows:*

(a) On vessels less than 80 feet (24.38 m) in beam, at least one of such design and placement that it can be easily read by day or night from all normal conning positions and from the steering station.

(b) On vessels 80 feet (24.38 m) or more in beam, at least one inside the wheelhouse and one on each bridge wing, of such design and placement so that at least one can be easily read by day or night from each conning position and from the steering station.

(c) They shall show in degrees clearly and accurately the position and direction of the rudder or rudders. It shall be noted that indicators located aft of the conning positions will not be considered as meeting this requirement. Overhead rudder angle indicators located behind the pilot’s conning positions are not acceptable. Rudder angle indicators mounted on overhead panels should be located as close to the forward bulkhead as possible for most efficient viewing by the pilot.

(2) *Propeller revolution tachometer indicators as follows:*

(a) On vessels less than 80 feet (24.38 m) in beam, at least one for each propeller, of such design as to be easily read by day or night from all normal conning positions.

(b) On vessels 80 feet (24.38 m) or more in beam, at least one for each propeller located inside the wheelhouse and one for each propeller located on each bridge wing, of such design and placement so that at least one can be easily read by day or night from each conning position.

(c) Indicators shall show revolutions per minute clearly and shall accurately indicate the direction of the propeller or propellers. It shall be noted that indicators located aft of the conning positions will not be considered as meeting this requirement.

(d) All vessels with variable pitch control indicators will have them so located as required in (a) and (b) of this subsection.

(3) Controllable pitch propeller indicators as follows:

(a) On vessels less than 80 feet (24.38 m) in beam, at least one for each propeller, of such design as to be easily read by day or night from all normal conning positions.

(b) On vessels 80 feet (24.38 m) or more in beam, at least one for each propeller located inside the wheelhouse and one for each propeller located on each bridge wing, of such design and placement so that at least one can be easily read by day or night from each conning position.

(4) Indicators must be operational: Vessels with missing or broken indicators may expect transit delays.

g. Very High Frequency (VHF) Radio - Every power-driven vessel of 300 gross tons or over, every power-driven vessel of 100 gross tons or over carrying one or more passengers for hire, and every commercial towing vessel of 26 feet (7.92 m) in length or over shall be equipped with at least one VHF transceiver as follows:

(1) Must be operable from the navigational bridge and located near Conning Position 1.

(2) Must be equipped with International Channels 12 (156.00 MHz), 13 (156.650 MHz) and 16 (156.800 MHz).

h. Whistle Controls - Vessels shall be provided with whistle controls as follows:

(1) On all vessels, one within easy reach on the navigational bridge from Conning Positions 1, 2 and 3, as described in paragraph 4.d of this section, preferably on the forward bulkhead.

(2) If the beam of the vessel is over 49.2 feet (15 m), additional controls shall be provided within 5 feet (1.52 m) of the extreme end of bridge wings at Conning Positions 4 and 5.

(3) Controls shall make it possible to regulate precisely any required whistle signal.

i. Steering Light

(1) All vessels over 328 feet (100 m) in length shall have installed, at or near the stem, a steering range equipped with a fixed blue light which shall be clearly visible from the bridge along the centerline. The height of the light is to be as close as possible to the height of eye level on the bridge. If said range and light so placed would be partially or completely

obscured from Conning Position 1, then two such ranges and lights must be installed ahead of Conning Positions 2 and 3. The wheelhouse position directly aft of the steering lights shall be marked with a small labeled plaque on the window sill which can be located in the dark by feel.

(2) Naval or military vessels exempted from the requirements of 72 COLREGS (*see ACP Navigation Regulations, Article 108*) shall also be exempted from the requirements of this article.

(3) The light required shall be capable of being illuminated and extinguished by a suitable rheostat or control switch located either on the navigation bridge or forecastle deck, or both.

(4) The use of this steering light shall be at the discretion of the Canal pilot who has control of the navigation and movement of the vessel.

j. Bow/Stern Thrusters - Vessels equipped with bow/stern thrusters should provide controls located at the extreme ends of the bridge wings, as well as inside the wheelhouse.

k. Compass

(1) Ships of 150 gross tonnage (ITC69) and over shall be fitted with a standard magnetic compass and with a steering compass unless the information provided by the standard compass is made available and is clearly readable by the helmsman at Conning Position 1. Means must be available for taking bearings, as nearly as practicable over an arc of the horizon of 360°. Residual deviation of the magnetic compass must be verified to be less than 7 degrees by swinging the vessel on various headings. Such verification by a recognized calibration authority must have been accomplished, and an accurate deviation table issued, within the previous 12-month period. If necessary, the compass must be adjusted to reduce the observed deviation to less than 7 degrees. Calibration cards issued and signed by the master will be accepted as long as the deviation is less than 6 degrees. Ships of less than 150 gross tonnage shall be fitted with a steering compass and have means for taking bearings.

(2) Ships of 500 gross tons (ITC69) and over shall be fitted with a gyro compass. The master gyro compass or a gyro repeater shall be clearly readable by the helmsman from the main conning position. On ships of 1,600 gross tonnage (ITC69) and over, a gyro repeater or gyro repeaters shall be provided and shall be suitably placed for taking bearings as nearly as practicable over an arc of the horizon of 360°. A gyro repeater shall be provided which shall be readily visible and useable by the pilot from Conning Position 1. Maximum residual steady state gyro error shall not exceed 2°. The maximum divergence in reading between the master compass and repeaters under all operational conditions should not exceed plus or minus 0.5°.

(3) Vessels not in full compliance with these requirements should expect transit delays during periods of fog or inclement weather, a common occurrence in the Republic of Panama coincidental with the rainy season (May to December).

NOTE: *The ACP now requires that whenever a magnetic compass is calibrated or repaired in Panama Canal waters, the vessel's master must sign the ACP boarding officer's inspection checklist, corroborating that the magnetic compass was serviced using the appropriate procedures and that the equipment is in proper working order for the transit. A*

compass deviation card issued in Panama Canal waters without the corroborating signature of the master will not be accepted as valid and will be considered as a vessel deficiency.

l. Course Recorders - Vessels fitted with devices for recording engine orders and responses, movement of the rudders and changes in the ship's heading shall have them operating while navigating in Canal waters.

m. Bridge Wing Spotlights - A spotlight or searchlight capable of illuminating the side of the vessel at the waterline is required to be fitted at the extreme end of each bridge wing on all vessels whose maximum beam is 98.4 feet (30 m) and over. For all vessels, such lights should preferably be hinged type located on the after portion of the bridge wing to allow them to be swung out of the way behind the bridge wing, when not in use, or mounted below the bulwark if fitted forward. The normal work position of the pilot on the bridge wing is at the forward outboard corner where he can look forward and down, as well as over the side and aft. Lights, bearing repeaters and other equipment must not interfere with the pilot's ability to do that.

n. Radar

(1) Ships of 500 gross tonnage (ITC69) and over shall be fitted with a properly functioning radar installation.

(2) Ships of 10,000 gross tonnage (ITC69) and over shall be fitted with two properly functioning radar installations, each capable of being operated simultaneously with and independently of the other.

o. Main Propulsion Systems

(1) Notwithstanding that the propulsion is controlled from the bridge or the engine room, the maximum allowable response time ahead or astern for transiting vessels shall be 10 seconds or less.

(2) Vessels having main engines arranged for air starting, shall have enough starting air capacity to produce twelve consecutive starts for reversible main engines and six consecutive starts for non-reversible main engines without recharging the air containers.

(3) Vessels having main engines arranged for air starting, shall have at least two air compressors, capable of charging the main air containers in no more than 60 minutes to the requirements of Paragraph 4.o(2) .

(4) Where remote control of propulsion machinery is provided, the remote control of propulsion machinery shall be in good operating conditions.

(5) In the event of failure in any part of the automatic or remote control systems, it shall be possible for the propulsion machinery to be controlled from a local position.

(6) At least two independent means shall be provided for communicating orders from navigation bridge to the position in the machinery space or in the control room from which the engines are normally controlled: one of these shall be an engine room telegraph which provides visual indication of the orders and responses both in the machinery space and on the navigation bridge.

(7) Where remote control of propulsion machinery from the navigation bridge is provided, an alarm on the navigation bridge and in the machinery space must indicate when a low starting air pressure condition exist. This alarm shall be set at a level to permit further main engine starting operations.

(8) Internal combustion engines intended for the propulsion of the ship shall have their external high-pressure fuel delivery lines between the high-pressure fuel pumps and fuel injectors, protected with a jacketed piping system capable of containing fuel from a high-pressure line failure. A jacketed pipe incorporates an outer pipe into which the high-pressure fuel pipe is placed, forming a permanent assembly.

p. Use of Automatic Identification System (AIS)

The ACP has implemented mandatory carriage of Automatic Identification Systems (AIS) in Panama Canal waters. In order to be accepted for transit through the Panama Canal, all vessels over 300 gross tons or over 20 meters LOA must be equipped with an AIS transponder that meets the standards set by the International Maritime Organization (IMO). With regard to combined and multiple units (tug-and-tows), only the tug will be required to be equipped with an AIS transponder.

Shipboard AIS transponders shall comply with the following requirements:

(1) The AIS system installed onboard ships shall be Class A AIS ship borne equipment according to IMO MSC 74 (69) Annex 3, "*Recommendation on Performance Standards for a Universal Ship borne Automatic Identification Systems (AIS)*", as amended.

(2) The AIS equipment shall be type-approved according to standard IEC 61993-2. The Panama Canal Authority may require presentation of the type approval document. Some transponders have old firmware versions, which will not function properly. The make and model of these units, however, may be the same as those of the newer type-approved version. Normally, this condition can be corrected by installation of a newer firmware version in the AIS equipment and obtaining the type approval papers.

(3) The AIS equipment shall be installed according to IMO "*Guidelines for Installation of Ship borne Automatic Identification System (AIS)*", including the installation of a Pilot Plug. The Pilot Plug shall be close to conning position No. 1 on the navigation bridge. This plug shall be labeled "AIS PILOT PLUG", and shall have nearby a USA standard (NEMA 5-15R) 120V, AC, 3-prong power receptacle, to provide power to the pilot's laptop computer. This receptacle shall be connected to emergency power.

The IMO "*Guidelines for Installation of Shipborne Automatic Identification System (AIS)*" are available on the web page of the IMO at the following address: http://www.imo.org/includes/blastData.asp/doc_id=2741/227.pdf

The ACP has been monitoring the signals sent by ships already fitted with AIS. Some of these signals reveal deficiencies, which would make them unusable for transiting the Panama Canal. The most common deficiencies found so far are:

(1) Ship's static data is loaded incorrectly or not present at all. For example, we have seen ships reporting dimensions that are, obviously, incorrect.

(2) Some ships are not transmitting heading information. The connection of the ship's gyro to the AIS is required.

(3) On some ships, although the AIS system seems to be connected to the gyro compass, the heading information we are receiving shows the vessel with a different heading than the actual heading of the vessel.

(4) Some ship borne AIS stations do not respond to shore station commands, especially AIS Message 16, which is the "Assigned Mode" command, and AIS Message 17, which is "DGNSS broadcast binary message". The cause is probably outdated firmware. All AIS ship borne units shall use Message 17 data when received to correct the internal GPS position and use it to broadcast its position.

(5) Incorrect location of the Pilot Plug on the bridge and/or the installation not following IMO's "*Guidelines for Installation of Ship borne Automatic Identification System (AIS)*".

Experience has shown that harnessing today's leading-edge maritime technology reaps a rich harvest of benefits. The Panama Canal Authority has participated extensively in AIS discussions at the IMO, as well as in the technical meetings at IEC and IALA. Shore side AIS stations have been in place for testing since May 2002. The benefits of this satellite-based vessel navigation aid for commercial vessels will apply to all Panama Canal users. Reduced delays, improved safety, increased security and better logistical management of ship, canal, and dock assets are just some of the benefits of this system, which will generate improvements in efficiency in an increasingly cost-conscious world.

The amendments to Regulation 19, Chapter V, of the International Convention for the Safety of Life at Sea (SOLAS 74) replaced the existing subparagraphs .4, .5 and .6 of paragraph 2.4.2 with a new subparagraph .4 that requires all vessels, other than passenger ships and tankers, of 300 gross tonnage and upwards, but less than 50,000 gross tonnage, to have AIS installed not later than their first safety equipment survey conducted between the dates of July 1 and December 31, 2004. Subparagraphs .1, .2, and .3 of paragraph 2.4.2 of this same regulation remain in effect. Passenger ships and Tankers are covered by subparagraphs .1 and .2, respectively. However, the Panama Canal recognizes that not all vessels will have their permanent AIS systems installed until December 31, 2004; therefore, vessels will have the choice of a rental AIS ready vessel tracking portable unit from the ACP.

In addition, the Panama Canal will make an exception with older ships that only have 100VAC to 110VAC electrical service available on the bridge, instead of the required 120VAC, as well as with those vessels that have a 2-prong USA standard electrical outlet, instead of the required 3-prong outlet. This lower voltage and type of outlet (NEMA 1-15R) will be acceptable; however, the Canal will not accept vessels with 220-240 VAC electrical service.

Finally, vessels equipped with an AIS system that is not working properly, or it is not programmed properly, will be required to use a rental portable AIS-ready vessel tracking unit for the transit, which will be charged to the vessel.

q. *Steering Gear*

- (1) All crew members working on the bridge must be familiar with the steering gear switch-over procedures and with the use of emergency steering device.
- (2) Steering gear controls at the wheelhouse shall provide for the expedite change-over from steering Follow-Up mode to Non Follow-Up mode, within the helmsperson position at the bridge.
- (3) In the event of a power failure to any one of the steering gear power units, an audible and visual alarm shall be given on the navigation bridge.
- (4) The main steering gear and rudder stock shall be capable of putting the rudder over from 35° on one side to 35° on the other side with the ship at its deepest seagoing draught and running ahead at maximum ahead service speed and, under the same conditions, from 35° on either side to 30° on the other side in not more than 28 seconds.
- (5) The auxiliary steering gear should be capable of putting the rudder from 15° on one side to 15° on the other side in not more than 60 seconds.
- (6) Where the auxiliary steering is not provided and the main steering gear comprises of two or more identical power units, for a:
 - (a) Passenger ship, the main steering gear shall be capable of operating the rudder to the requirements of Section 4, part q.4., while any one of the power units is out of operation.
 - (b) Cargo ship, the main steering gear shall be capable of operating the rudder to the requirements of Section 4, part q.4., while all of the power units are in operation.

5. Requirements for Non-Self-Propelled Vessels

- a. Non-self-propelled vessels, other than integrated tug-barge combinations, will be accepted only on an individual basis; advance permission for initial transit as a non-self-propelled vessel is required. Displacement of these vessels is limited to 35,000 long tons and the draft requirements of paragraph 2.f of this Notice are applicable.
- b. The draft of non-self-propelled barges 550 feet (167.64 m) or more in length may be limited when in the opinion of the Canal Authority such limit is necessary to insure reasonable safety.
- c. Upon arrival, the tug will break up the tow and secure the bridle so no part of it extends below the surface of the water.
- d. Tows should have the capability of anchoring.
- e. All tows will be inspected before being scheduled for transit. **For safety reasons and to ensure that important details are not overlooked, inspections will normally be performed in the inner harbor and during day light hours.**
- f. Agents, operators and/or owners will be responsible to make any required alterations or additions to equipment or stowage.

- g. Boarding facilities will comply with Regulation No. 17, Chapter V, International Convention for Safety of Life at Sea (SOLAS). For tows with freeboards of 30 feet (9 m) or more, this also includes provisions for a nine-meter rig as described in paragraph 10.i(2) of this Notice.
- h. There must be a clear passage free of obstructions from the boarding facility to all working areas; otherwise, catwalks with handrails and steps must be provided. Figure 5 is a sketch of a catwalk and ladder acceptable to the Authority.
- i. The working area near chocks and bitts on all dead tows must be clear of obstructions and fitted with safety rails or lines at the vessel's sides.
- j. Tows must provide a pilot shelter with a clear view forward on the center line, about midway between the bow and stern. This shelter may be permanent or portable, but must protect the pilot from the elements. All tows with beam in excess of 80 feet (24.38 m) shall provide pilot shelters at the extreme beams from which the pilots may readily view the vessel's sides.
- k. Dead tows must be equipped with the chocks and bitts as set forth in the *ACP Navigation Regulations, Articles 59 and 60*.
- l. Tows must provide mooring and heaving lines in good condition, and have mooring arrangements and bitts or cleats for securing tugs that do not interfere with those chocks and bitts required for locomotive wires.
- m. All barges will be fitted so that a pusher tug can be secured with its stem held firmly to the centerline of the barge. Pushing tugs are to be equipped with wire cable snubbers and springs.
- n. Barges with poor visibility forward will be assigned additional tug assistance for their transit. The commercial tug may be placed in the notch or on a hawser at the discretion of the Transit Operations Division Executive Manager. The determination of what constitutes poor visibility will be made by the Transit Operations Division Executive Manager. The suitability of additional commercial tugs used in the transit will also be determined by the Transit Operations Division Executive Manager.
- o. Riding crews must be provided in sufficient numbers, as required by the Transit Operations Division Executive Manager, to safely handle tugboat lines and boarding ladders, and to assist in mooring. While underway in Canal waters, anchors shall be manned and ready to be dropped in case of emergency.
- p. Agents, operators and owners of dead tows are urged to contact the Transit Operations Division Executive Manager, as early as possible, but not later than 48 hours prior to ETA, so that particular requirements essential to planned transits can be met without delay.

6. Vessels Requiring Towing Services

a. Vessels arriving at either Panama Canal entrances having a mean draft in excess of the allowable draft under the Load Line Regulations for the tropical zone applicable (as determined by the American Bureau of Shipping, Lloyd's Register, or other acceptable certifying agency) are required to use the services of one or more ACP tugboats. These towing services will be required in the following Canal areas:

- (1) From Buoys 1 and 2 in the Pacific entrance channel to Gamboa Reach, and vice versa.
- (2) From the north end of Gatun Locks to Buoy 3 in the Atlantic Entrance Channel, and vice versa.

b. In cases where the overdraft is negligible, the assignment of one or more towboats may be waived at the discretion of the Canal Operations Captain or his designee.

c. The following conditions require that vessels be towed through the entire Canal, and the masters shall report these conditions and request the towing services:

- (1) Vessels without mechanical motive power;
- (2) Vessels with disabled machinery or bad steering, and
- (3) Vessels liable to become unmanageable for any other reason.

d. In addition, ACP authorities may require vessels to make use of one or more towboats through Gaillard Cut, on the approaches to the locks, or in any other part of the Canal, when, in their judgment, such action is necessary to ensure reasonable safety to the vessel and/or the Canal and its appurtenances.

e. The towing services in all of the above cases shall be chargeable to the vessel.

7. Deckload Cargo

a. As provided in the *ACP Navigation Regulations, Articles 72 and 73*, a vessel carrying a deck load shall have it so stowed as to be sufficiently clear to provide safe working space around all chocks, bitts, and other gear used in transiting and so arranged as to not obstruct any direct lead from chock to bitts.

b. Deck cargo shall be so stowed to provide safe passage to and from necessary working areas. If access to working spaces is necessary over a deck load, as with lumber, a catwalk will normally be required, unless a leveled, continuous surface free of encumbrances such as lashings is already provided. When catwalks are required they shall be at least 3 feet (0.915 m) in width and provided with adequate guard rails. Where the deck cargo is sufficiently level for gangway purposes without a catwalk, the guard rails, or life lines, spaced not more than 12 inches (30.5 cm) apart vertically, must be provided on each side of the deck cargo to a height of at least 4 feet (1.20 m) above the cargo.

- c. If deck access is provided on deck adjacent to deck cargo, a leveled continuous passage at least 3 feet (0.915 m) in width shall be provided. This access shall be unencumbered by shoring, lashings or other obstacles deemed hazardous to normal passage. Height over passageway may not be less than 7 feet (2.134 m).
- d. When personnel are required to traverse over deck cargo, ladders adequate for safe access must be provided between the deck and top of deck cargo. Such ladder must be provided with guardrails or safety lines as previously described for catwalks.
- e. Deck cargo shall be stowed securely to prevent any shifting or displacement during access to working spaces by personnel.
- f. Vessels may transit with deck cargo protruding over one side only, not to exceed 15 feet (4.572 m); but the maximum beam, including protrusions, must not exceed 85 feet (25.90 m).
- g. An adequate bulwark or railing shall be provided between deck cargo and the ship's side.
- h. All sharp edges and projections on deck cargo adjacent to normal accesses shall be adequately protected to prevent injury to personnel.
- i. Sufficient lighting shall be provided by the vessel to illuminate deck accesses and working spaces during hours of darkness.
- j. Figure 5 shows sketches of a catwalk and ladder acceptable to the Authority.

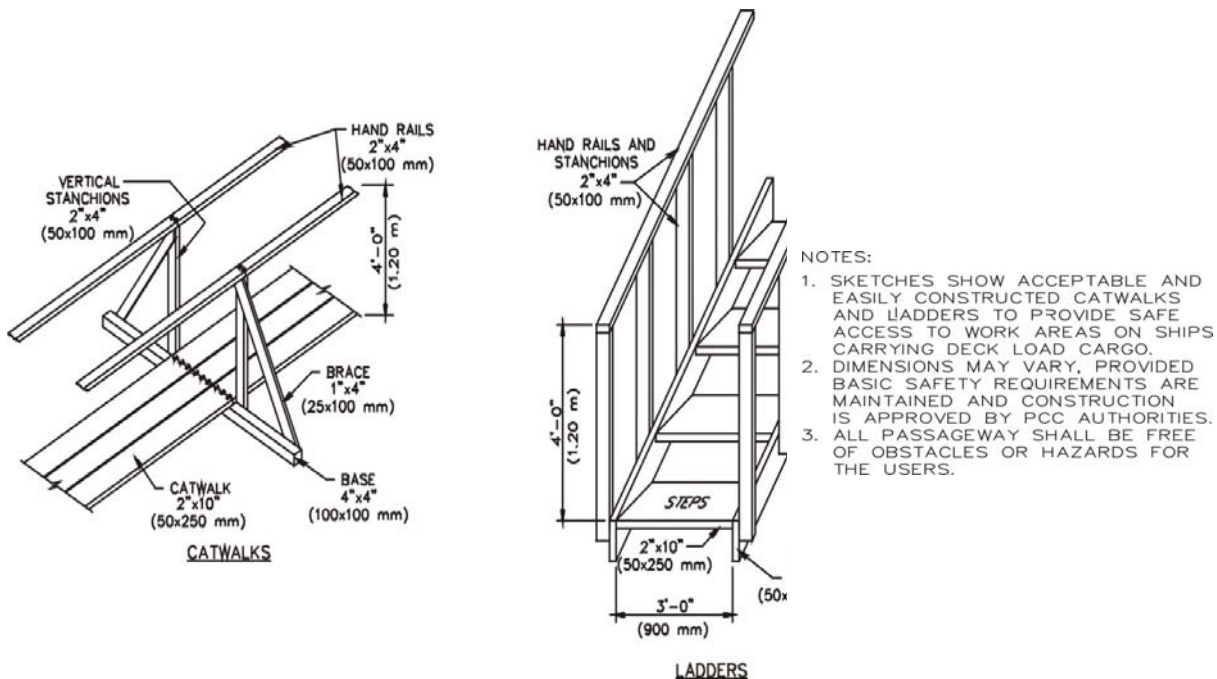

FIGURE 5 - Catwalk and Ladder Sketches

8. Construction, Number and Location of Chocks and Bitts

a. A vessel passing through the locks shall normally be assisted by electric locomotives using steel towing wires. At the discretion of the Transit Operations Division Executive Manager, certain vessels, usually those under 125 feet (38.10 m) in length, may be handled with their own lines either against the lock wall or from both walls in the center of the chamber. Vessels transiting the Canal are required to have chocks and bitts as follows:

(1) All chocks for towing wires shall be of heavy closed construction and shall have a convex bearing surface with a radius of not less than 7 inches (180 mm). The convex surface shall extend so that a wire from the bitt, or from the locks locomotive through the chock, shall be tangent to the 7 inches (180 mm) radius at any angle up to 90 degrees with respect to a straight line through the chock.

(2) No part of the vessel which may be contacted by the towing wires, at any angle, shall have less than a 7-inch (180 mm) radius.

(3) Chocks designated as single chocks shall have a throat opening of not less than 100 square inches (650 square cm) in area — preferred dimensions are 12 x 9 inches (305 mm x 230 mm) — and shall be capable of withstanding a strain of 100,000 pounds (45,360 kg) on a towing wire from any direction.

(4) Chocks designated as double chocks shall have a throat opening of not less than 140 square inches (900 square cm) in area — preferred dimensions are 14 x 10 inches (355 mm x 255 mm) — and shall be capable of withstanding a strain of 140,000 pounds (64,000 kg) on the towing wires from any direction.

(5) Use of existing roller chocks is permissible provided they are not less than 49 feet (15 m) above the waterline at the vessel's maximum Panama Canal draft and provided they are in good condition, meet all of the requirements for solid chocks as specified in paragraphs 3.8.a(1), 3.8.a(2), 3.8.a(3) and 3.8.a(4) of this section, as the case may be, and are so fitted that transition from the rollers to the chock body will prevent damage to towing wires. **However, roller chocks are not accepted in plans of new constructions which are submitted for approval as per paragraph 2.i of this Notice.**

(6) Each single chock shall have an accompanying bitt — preferred diameter of 14 inches (356 mm) — capable of withstanding the stress caused by a load of 100,000 pounds (45,360 kg).

(7) Each double chock located at the stem and the stern, in accordance with paragraph 8.a(8) of this section, shall have two pairs of accompanying heavy bitts with each bitt of each pair — preferred diameter of 16 inches (406 mm) — capable of withstanding the stress caused by a load of 140,000 pounds (64,000 kg). Other double chocks shall have a pair of accompanying heavy bitts with each bitt capable of withstanding a strain of 140,000 pounds (64,000 kg).

(8) All vessels, except those not requiring locomotives, shall be fitted with a double chock set athwartships right in the stem and another double chock set athwartships right in the stern, except that on vessels of less than 75 feet (22.86 m) in beam, two single chocks may be substituted for each double chock required by this subsection; on vessels of over 75 feet

(22.86 m) in beam two double chocks may be substituted. If such substitution is made, the chocks shall be placed port and starboard not more than 8 feet (2.5 m) abaft the stem or 10 feet (3 m) forward of the stern, provided that these chocks are not more than 10 feet (3 m) from the center line of the vessel.

(9) Vessels under 200 feet (60.96 m) in length and less than 50 feet (15.24 m) in beam shall have a double chock or two single chocks at the stem and stern. If the vessel is equipped with the two single chocks they shall be placed, port and starboard, not more than 8 feet (2.5 m) abaft the stem or 10 feet (3 m) forward of the stern, and not more than 10 feet (3 m) off the center line (see Figure 6).

(10) Vessels from 200 up to 400 feet (60.96 m to 121.92 m) in length and not exceeding 75 feet (22.86 m) in beam shall have a double chock at the stem and at the stern or two single chocks at the bow and stern, port and starboard, not more than 8 feet (2.5 m) abaft the stem or 10 feet (3 m) forward of the stern and not more than 10 feet (3 m) off the center line and shall have two additional single chocks, port and starboard, 30 to 50 feet (9 to 16 m) abaft the stem and 30 to 50 feet (9 to 16 m) forward of the stern (see Figure 6).

(11) Vessels from 400 up to 570 feet (121.92 m to 173.74 m) long and not more than 75 feet (22.86 m) in beam shall have a double chock at the stem and stern or two single chocks at the bow and stern, port and starboard, not more than 8 feet (2.5 m) abaft the stem or 10 feet (3 m) forward of the stern and not more than 10 feet (3 m) off the center line. In addition, these vessels shall have a double chock, port and starboard, 40 to 50 feet (12 m to 16 m) abaft the stem, a single chock port and starboard, 80 to 90 feet (24 m to 28 m) abaft the stem, and a single chock, port and starboard, 40 to 50 feet (12 m to 16 m) forward of the stern (see Figure 6).

(12) Vessels over 570 feet (173.74 m) long or 75 feet (22.86 m) in beam or over shall have a double chock at the stem and stern or two double chocks at the bow and stern, port and starboard, not more than 8 feet (2.5 m) abaft the stem or 10 feet (3 m) forward of the stern and not more than 10 feet (3 m) off the center line. In addition, these vessels shall have a double chock, port and starboard, 40 to 50 feet (12 to 16 m) abaft the stem; a single chock, port and starboard, 80 to 90 feet (24 to 28 m) abaft the stem; a double chock, port and starboard, 40 to 50 feet (12 to 16 m) forward of the stern and a single chock, port and starboard, 80 to 90 feet (24 to 28 m) forward of the stern. On vessels over 900 feet (274.32 m) in length with maximum beam of 91 feet or more extending to the stern, the double chocks required on port and starboard, 40 to 50 feet (12 to 16 m) forward of the stern, shall be located no less than 42.65 feet (13 m) above the waterline at the maximum Panama Canal fresh water draft of the vessel.

(13) All vessels with a maximum beam of 91 feet (27.73 m) or more, in addition to the double chock at the stern, which is required by Paragraph 8.a (12) above, shall have two single chocks on the stern. One chock shall be to port of the centerline and one chock shall be to starboard of the centerline. The single chocks shall be symmetrically spaced not less than 10 feet (3 m) nor more than 20 feet (6 m) from the centerline.

(14) Vessels with large flared bows, pronounced counters astern or unusually high freeboard, such as container vessels or vehicle carriers, will be required to provide single closed chocks located further aft than those required in Paragraph 8.a (12) of this Section

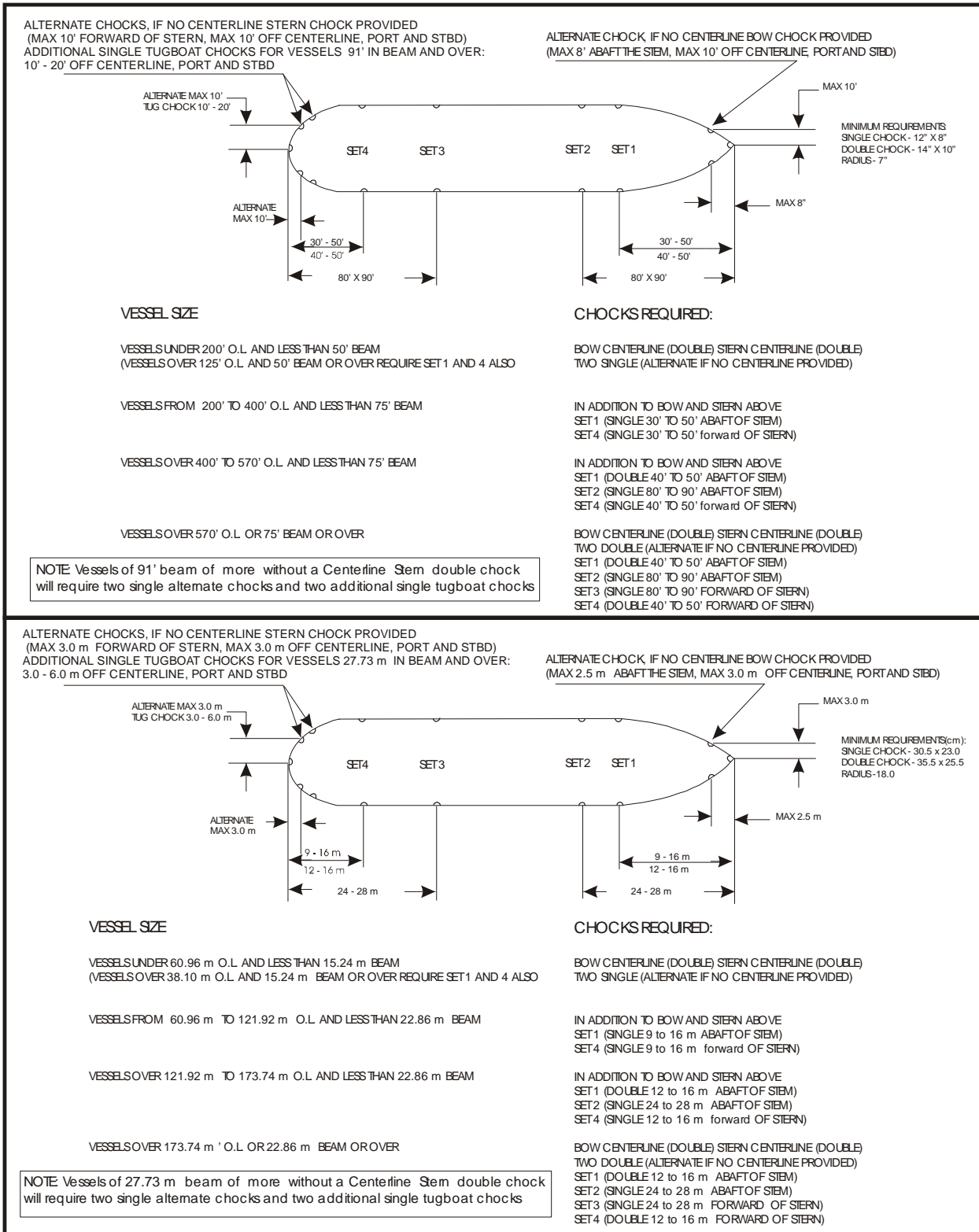

FIGURE 6 – Location of Chocks and Bits

for correct positioning of assisting tugs, or may be required to fit recessed tug bollards into the hull so that tugs can work without coming in contact with the bow flare or without requiring extra long lines and/or inefficient leads (see Figure 6).

(15) Where recessed hull bitts are installed in the hull, they shall be installed not less than 12 feet (3.7 m) and not more than 15 feet (4.6 m) above the vessel's waterline. Vessels that have an appreciable variation in draft may be required to install two sets of recessed hull bitts so that one bitt is located over the other bitt. Also, the recessed hull bitts are to be installed in the hull as far forward as possible, both port and starboard sides, where the bow flare does not exceed 25 degrees as measured from the vertical line of the vessel's side. This position may require locating the chocks and bitts further aft than the 80 to 90 feet (24 to 28 m) abaft the stem as in paragraph 8.a (11) above. This position will allow ACP tugboats to work safely under the bow flare without the tugboats' mast or pilothouse coming in contact with the vessel's hull.

(16) A vessel not requiring locomotives shall have a chock arrangement similar to that described in paragraph 8.a (9) of this Notice, except that the chocks need only be single chocks or, if approved by the Canal Authority, of lesser strength.

(17) Any vessel that fails to meet these requirements may be denied transit. If the Executive Vice President of Operations or his representative decides that the vessel can be handled without undue danger to equipment or to personnel, notwithstanding her failure to comply with other requirements of this section, the vessel may be allowed to transit after executing a release. The master of the vessel must sign an undertaking for the vessel, her owners, operators or any other persons having any interest in her, and for himself, releasing the Authority from and indemnifying it against any loss, damage or liability incurred by the Canal Authority to the extent and in the proportion that such failure to meet the requirements of this section proximately causes or contributes to the casualty and resulting damages.

(18) **All new vessels are expected to comply with all current vessel requirements.** Pre-existing vessels are granted a waiver for one round trip or for one year from the date of the waiver, whichever comes first. Certain tank vessels, and other vessels that prove to the satisfaction of the Authority that the work necessary to fit the chocks on the stern cannot be safely performed while at dockside, will be provided with a waiver extending until the next yard overhaul. **Vessels with ACP approved recessed bitt on the stern may, upon written application, be exempted from this requirement.**

(19) Adequate working space shall be provided on deck areas adjacent to winches, capstans, chocks, bitts and fairleads and along the path of mooring lines at least 3 feet (0.915 m) in width. This space shall be unencumbered by shoring, lashings or other obstacles deemed hazardous to normal passage or work by line handlers. Height over these areas may not be less than 7 feet (2.134 m). The working space provided along the path of the mooring lines and beside the bitts must be sufficient so that three linehandlers can pull the lines aboard without using winches or capstans.

b. For further information contact the Transit Operations Division Executive Manager.

9. Mooring Lines, Anchors and Deck Machinery

- a.** Vessels are required to have on deck six manila or synthetic mooring lines forward and six aft in good conditions prior to commencing transit. The size and strength suitable for the vessel to dock, moor at a lock approach wall or secure in a lock chamber are the vessel's responsibility. The master shall inform the Boarding Officer whether or not the vessel complies with the above, so that he may advise Maritime Traffic Control Unit. Wire ropes and ropes composed of both wire and fiber or filaments, are not acceptable for Canal operations and shall not be used.
- b.** These lines are required to be on deck prior to commencing transit and ready for immediate use. Each line shall be at least 250 feet (75 m) in length and shall have an eye of at least five feet (1.50 m) spliced in one end. If one of these lines is 500 feet (150 m) or more in length with an eye in each end, it will qualify as two lines for the purpose of this requirement. They shall be in good condition. Non-compliance with this requirement could result in transit delay.
- c.** Anchors and deck machinery shall be operational at all times.
- d.** All mooring winches shall be capable of retrieving the lines used for pulling the locomotive wires onboard at a rate of 120 feet (37 meters) per minute. The master shall inform the ACP Boarding Officer whether or not the vessel complies with this requirement. Additional Canal deckhands or other resources may be assigned in case of winches are not working or are with limited capabilities.
- e.** Anchors shall be retrieved at a rate of 3 minutes per shot (27 meters).

10. Boarding Facilities

- a.** The Authority considers proper boarding facilities to be an absolute necessity to ensure the safety of operations personnel and others using these facilities in Canal waters. Poorly constructed, installed, maintained or operated boarding facilities are not acceptable for use in Canal waters. Requirements for boarding facilities are defined in the *ACP Navigation Regulations, Articles 57 and 58*. Vessels with unsafe or inadequate boarding facilities will be required to correct such deficiencies before transiting and lengthy delays may result. Figure 7, on page 38, is a pictorial representation of acceptable boarding facilities that comply with Canal standards.
- b.** Safe boarding facilities should be available through the entire transit for pilots and Canal deckhands. Improper boarding facilities may delay the transit or, if deemed safe by the Authority, may require use of a tug to hold the vessel dead in the water during boarding or disembarking operations. This is considered a vessel deficiency, therefore the tug will be charged to the vessel.
- c.** Boarding facilities of vessels arriving the Canal shall comply with the requirements shown below, which conform with Regulation 17, Chapter V, International Convention for Safety of Life at Sea (SOLAS), including all current amendments, annexes and resolutions.

d. General

(1) All arrangements used for ACP personnel or other transfers shall efficiently fulfill their purpose of safely enabling embarking and disembarking. The appliances shall be kept clean, properly maintained and stowed and shall be regularly inspected to ensure that they are safe to use. They shall be used solely for the embarkation and disembarkation of personnel.

(2) The rigging of the transfer arrangements and the embarkation and disembarkation of ACP personnel or others shall be supervised by a responsible officer with means of communication with the navigation bridge, who shall also arrange for the escort of the pilot by a safe route to and from the navigation bridge, and the deckhands to and from their designated work stations. Personnel engaged in rigging and operating any mechanical equipment shall be instructed in the safe procedures to be adopted. All boarding equipment shall be tested in operating position by the vessel's personnel prior to use by Authority personnel.

e. Transfer Arrangements

(1) Arrangements shall be provided to enable ACP personnel or others to embark and disembark safely on either side of the ship. All vessels shall have, weather permitting, both an accommodation ladder and a pilot ladder rigged and ready for use upon arrival in Canal waters.

(2) When it is intended to embark and disembark ACP personnel or others by means of the accommodation ladder, or by means of mechanical pilot hoists or other equally safe and convenient means in conjunction with a pilot ladder, the ship shall carry such equipment on each side, unless the equipment is capable of being transferred for use on either side.

f. Safe and convenient access to, and egress from, the ship shall be provided by both a pilot ladder and an accommodation ladder. Mechanical pilot hoists or other boarding devices must be approved by the Authority and may be used at the option of the pilot or line handlers.

(1) Pilot ladders

(a) The ladder shall be safe, convenient and efficient for the purpose of enabling the pilots to embark and disembark safely, kept clean and in good order and may be used by officials and other persons while a ship is arriving or leaving a port.

(b) The ladder shall require a climb of not less than 5 feet (1.5 m) and not more than 30 feet (9 m) above the surface of the water.

(c) The ladder shall be so positioned that it is clear from any possible discharges from the ship, that it is within the parallel mid-body length of the ship and, as far as is practicable, within the mid-ship half-length of the ship.

(d) Each step shall rest firmly against the ship's side; where constructional features, such as rubbing bands, would prevent the implementation of this provision, special arrangements shall be made to the satisfaction of the Authority to ensure that persons are able to embark and disembark safely.

(e) A single length of ladder shall be used capable of reaching the water from the point of access to, or egress from, the ship; in providing for this, due allowance shall be made for all conditions of loading and trim of the ship and for an adverse list of 15 degrees. Whenever the distance from sea level to the point of access to the ship is more than 30 feet (9 m), access from the pilot ladder to the ship shall be by means of an accommodation ladder or other equally safe and convenient means.

(f) The securing strong points, shackles and securing ropes shall be at least as strong as the side ropes.

(g) The steps of the pilot ladder shall comply with the following requirements:

- If made of hardwood, they should be made in one piece, free of knots or other defects. If made of material other than hardwood, they should be of equivalent strength, stiffness and durability to the satisfaction of the Authority.
- The four lowest steps may be made of rubber of sufficient strength and stiffness or other material to the satisfaction of the Authority.
- Steps shall have an efficient non-slip surface, and shall not be painted with an opaque color or high gloss paint. The grain and character of the step shall be visible in order that any cracks or defects may be readily visible to the person using the ladder.
- Should have not less than 16 inches (406 mm) between the inside surfaces of the side ropes. Steps should be not less than 4-1/2 inches (115 mm) wide, and 1 inch (25 mm) in depth, excluding any non-slip device or grooving.
- Should be equally spaced not less than 12 inches (305 mm) nor more than 15 inches (380 mm) apart and be secured in such a manner that each will remain horizontal.

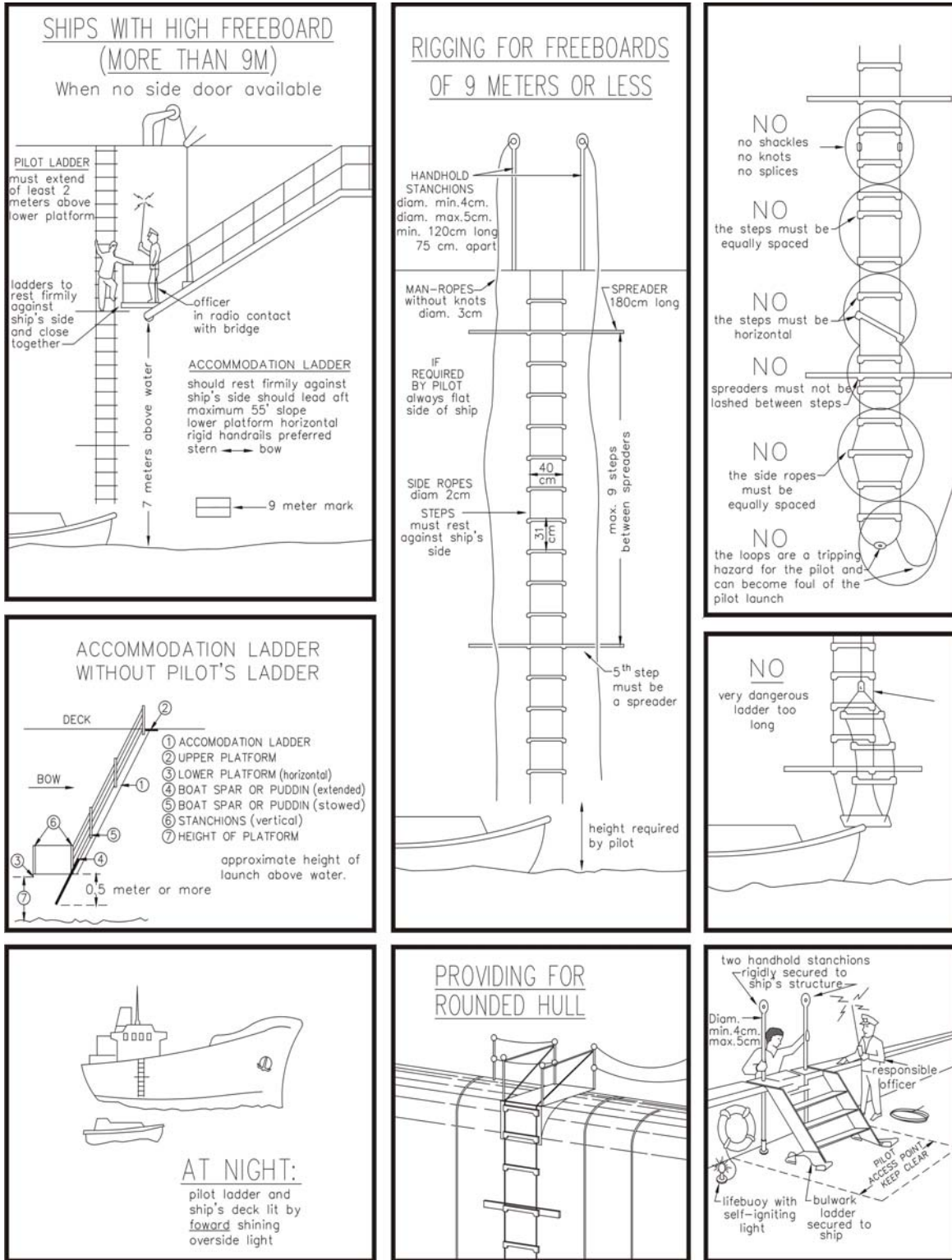

FIGURE 7 – Panama Canal Required Boarding Arrangements

(h) No pilot ladder shall have more than two replacement steps which are secured in position by a method different from that used in the original construction of the ladder, and any steps so secured shall be replaced as soon as reasonably practicable by steps secured at position by the method used in the original construction of the ladder. When any replacement step secured to the side ropes of the ladder by means of grooves in the sides of the steps, such grooves shall be in the longer sides of the steps.

(i) Pilot ladders with more than five steps should have spreader steps not less than 6 feet (1.8 m) long provided at such intervals as will prevent the pilot ladder from twisting. Such spreader steps or battens shall be made of the same material and construction as the other ladders steps. The lowest spreader step shall be on the fifth step from the bottom of the ladder and the interval between any spreader step and the next shall not exceed nine steps.

(j) The side ropes of the ladder shall consist of two uncovered ropes not less than 3/4 inch (20 mm) in diameter on each side. Each rope shall be continuous with no joints below the top step. Two manropes properly secured to the ship and not less than 1 inch (28 mm) in diameter shall be kept at hand ready for use.

(k) Side ropes shall be made of manila or other material of equivalent strength, durability and grip that has been protected against actinic degradation and is satisfactory to the Authority.

(l) A life buoy equipped with a self-igniting light should be kept at hand ready for use, as should a heaving line. Life buoys should not be attached to the ship.

(m) Lighting should be provided such that both the pilot ladder over side and the position where any person embarks or disembarks on the ship are adequately lit.

(2) *Accommodation ladders*

(a) Accommodation ladders should be sited leading aft, that is, with the lower platform at the after end. Accommodation ladders which lead forward or which do not rest firmly against the vessel's side are not considered safe for use by ACP personnel. When in use, the lower end of the accommodation ladder should rest firmly against the vessel's side within the parallel mid-body of the vessel and within the mid-ship half-length and clear of all discharges. A pilot ladder complying with the provisions of Paragraph 10.f(1) shall be kept on deck adjacent to the hoist and available for immediate use.

(b) The lower platform of the accommodation ladder shall be kept in a horizontal position when in use and it should be held at a distance above the water equal to the deck of the boarding launch. The boat spar shall be extended. Intermediate platforms, if so fitted, shall be self-leveling. Treads and steps of the accommodation ladder should be so designed that an adequate and safe foothold is given at the operative angles.

(c) The ladder and platforms shall have vertical safety stanchions and rails or lines equipped and rigged on both sides. If hand ropes are used, they should be tight and properly secured. The vertical space between the handrail or hand rope and the stringers of the ladder should be securely fenced.

(d) The length of an accommodation ladder used in combination with a pilot ladder as a nine-meter rig should be sufficient to ensure that its angle of slope doesn't exceed 55 degrees. The pilot ladder should be rigged immediately adjacent to the lower platform of the accommodation ladder and be secured at the edge of the lower platform with the pilot ladder hanging vertically. The pilot ladder should extend at least 6 feet 8 inches (2 m) above the lower platform and shall rest firmly against the ship's side within the parallel mid-body of the ship and, as far as is practicable, within the mid-ship half-length and clear of all discharges. The lower platform must be held at a level to allow for the height of the launch deck, plus the height of a person standing on the deck, plus the rise and fall due to swell; normally, 23 feet (7 m) above the water is sufficient.

(e) Lighting shall be provided at night such that the full length of the ladder is adequately lit.

(f) If a trap door is fitted in the lower platform of a combination accommodation ladder/pilot ladder to allow access from and to the pilot ladder, the aperture should not be less than 30 inches x 30 inches (750 mm x 750 mm) and of a design approved by the Authority. In this case the after part of the lower platform should also be fenced as specified in Paragraph 10.f (2) (c), and the pilot ladder should extend above the lower platform at least 6 feet 8 inches (2 m). The aperture on the lower platform must be open to the side of the vessel's hull to allow the pilot ladder to lay flat against the hull.

(g) Accommodation ladders, together with any suspension arrangements or attachments fitted and intended for use in the Canal, must be arranged to the satisfaction of the Authority.

(3) *Mechanical pilot hoists*

(a) A mechanical pilot hoist, if provided, shall be so located that it is within the parallel body length of the ship and, as far as is practicable, within the mid-ship half length and clear of all discharges.

(b) A mechanical pilot hoist and its ancillary equipment shall be of a type acceptable by the Authority. It shall be designed to operate as a moving platform or as a ladder to lift and lower one person on the side of the ship. It shall be of such a design and construction as to ensure that the pilot can be embarked and disembarked in a safe manner, including a safe access from the hoist to the deck and vice versa. Such access shall be gained directly by a platform securely guarded by handrails.

(c) The ladder shall consist of two parts. The first; a rigid upper part not less than 7-3/4 feet (2.5 m) in length, for the safe transportation of personnel upward or downward. The second and lower part consists of a short length of pilot ladder to allow personnel to climb from the pilot launch to the upper part and vice versa.

(d) The rigid ladder part should be equipped in such a way that the person carried can maintain a safe position while being hoisted or lowered. It should include sufficient non-slip steps to provide safe and easy access to and from the platform and safe handholds capable of being used in all conditions. The lower end of the rigid part must have a spreader, not less than 6 feet (1.8 m) in length and equipped with rollers which roll freely on the vessel's

side during the entire operation of embarking or disembarking. It must be fitted with an effective guard ring, suitably padded, so positioned as to provide physical support for the person carried without hampering movement. There must be adequate means of communication between the person carried and the officer who supervises the embarkation or disembarkation of the person carried.

(e) A hoist designed to operate as a lift platform should have a platform with a non-skid surface at least 30 inches x 30 inches (750 mm x 750 mm), exclusive of the surface area of any trapdoor in the floor. The platform should be limited to one person per square meter of floor area or fraction thereof, exclusive of the area of any trap door. If a trap door is provided, it should be at least 30 inches x 30 inches (750 mm x 750 mm), so arranged that a pilot ladder may be rigged through the trapdoor, extending and of a design approved by the Authority. In this case the platform should be fenced as specified in paragraph 10.f (2) (c), and the pilot ladder should extend above the lower platform at least 6 feet 8 inches (2 m). The aperture on the lower platform must be open to the side of the vessel's hull to allow the pilot ladder to lay flat against the hull. Each gate in the fence should have a latch to keep it securely closed. The lower platform must be held at a level to allow for the height of the launch deck, plus the height of a person standing on the deck, plus the rise and fall due to swell; normally, 23 feet (7 m) above the water is sufficient.

(f) Efficient hand gear shall be provided to lower or recover the person carried, and kept ready for use in the event of power failure.

(g) The hoist shall be securely attached to the structure of the ship. Attachment shall not be solely by means of the vessel's side rails. Two separate wire falls shall be used. The falls should be made of flexible steel rope of adequate strength, resistant to corrosion in a salt laden atmosphere and of sufficient length to allow for all conditions of freeboard likely to be encountered in service, and to retain at least three turns on the winch-drums with the hoist in its lowest position. Proper and strong attachment points shall be provided for hoists of the portable type on each side of the ship. The falls should be so arranged that the ladder or lift platform remains leveled if one fall breaks.

(h) If belting or rubbing bands are fitted in way of the hoist operation, such obstructions shall be cut back sufficiently to allow the hoist to operate against the flat of the vessel's side.

(i) A pilot ladder complying with the provisions of Paragraph 10.f (1) shall be kept on deck adjacent to the hoist and available for immediate use so it is available from the hoist at any point of its travel. The pilot ladder shall be capable of reaching the sea level from its own point of access to the vessel.

(j) The position on the vessel's side where the hoist will be lowered shall be indicated.

(k) From a standing position at the control point, it should be possible for the operator to have the hoist under continuous observation between its highest and lowest working points.

(l) Adequate lighting shall be provided to illuminate the position on deck where a person embarks or disembarks and the controls of the mechanical pilot hoist.

(m) A life buoy equipped with a self-igniting light should be kept at hand ready for use, as should a heaving line. Life buoys should not be attached to the ship.

(n) Two manropes properly secured to the ship and not less than 1 inch (28 mm) in diameter shall be ready for immediate use if required by the pilot.

(4) Ship side doors

Ship side doors used for pilot transfer shall not open outward. The point of ingress or egress must be no less than 5 feet (1.5 m) above the surface of the water. The opening used for embarking or disembarking shall not be less than 5 feet (1.5 m) wide and 7.2 feet (2.2 m) tall.

(5) Access to deck

(a) Means shall be provided to ensure safe and convenient and unobstructed passage for any person embarking or disembarking, between the head of the pilot ladder, or of any accommodation ladder or other appliance provided, and the vessel's deck.

(b) Where such passage is by means of a gateway in the rail or bulwark, adequate handholds or stanchions shall be provided.

(c) If passage is over the bulwark, a bulwark ladder shall be provided. The bulwark ladder shall be securely attached to the deck or bulwark to prevent overturning. Two handhold stanchions shall be fitted at the point of embarking or disembarking from the ship on each side.

(d) Handholds and handhold stanchions should not extend beyond the hull of the ship and should be free of protrusions such as loops, welded bars or pad eyes, and should be designed to allow the human hand to grasp any portion and slide up and down, as necessary, without removing the hand or releasing the grip. Handholds and stanchions should be not less than 2 feet 3 inches (0.7 meter) and no more than 2 feet 7 inches (0.8 meter) apart. Each stanchion shall be rigidly secured to the ship's structure at or near its base and also at a higher point. Handholds and stanchions shall not be less than 1 1/4 inches (32 mm) and no more than 2 inches (50 mm) in diameter, and shall extend not less than 4 feet (1.2 m) above the top of the bulwarks or point of ingress. Stanchions or handrails should not be attached to the bulwark ladder.

(e) Adequate lighting shall be provided to illuminate the position on deck where a person embarks or disembarks.

11. Tug Assistance to Single-Hull Tankers

The ACP will evaluate, on a case-by-case basis, single hull tanker vessels restricted by MARPOL regulations and assign, at the vessel's expense, any additional resources deemed necessary to guarantee a safe transit. Single hull tankers (single side/single bottom, single side/double bottom, or double side/single bottom) are assigned, as a minimum, an escort tug when they transit with cargo defined as "oils" in accordance with Definition (1), Regulation (1), Chapter (1) Annex 1 of MARPOL. The escort tugs are assigned, in each case, according to the following criteria:

(a) For tankers of 30,000 tons DWT and over, tugs will be assigned to assist all Canal entrances, locks approaches through Culebra Cut and across Gatun Lake.

(b) For tankers of 20,000 tons DWT and over, but less than 30,000 tons DWT, tugs will be assigned to assist at all locks approaches and through Culebra Cut.

(c) For tankers of 5,000 tons DWT and over, but less than 20,000 tons DWT, tugs will be assigned to assist at all locks approaches and through Culebra Cut.

(d) For tankers subject to Regulation 13H that are 600 tons DWT and over, but less than 5,000 tons DWT, tugs will be assigned to assist at all locks approaches and through Culebra Cut.

12. Admeasurement System for Full Container Vessels

The ACP admeasurement system for full container vessels reflects the international standard for a container (20-foot equivalent unit, TEU, measuring 20'x 8'x 8.5'). This measurement considers the full container carrying capacity of vessels (above and below deck), taking into account the visibility limitation imposed by the Panama Canal.

The following table provides the conversion ratio for different container sizes to a standard TEU measurement:

CONTAINER SIZE	RATIO (FT ³)	EQUIVALENCY
20' x 8' x 8.5'	1,360/1,360	1.00 TEUS
20' x 8' x 9.5'	1,520/1,360	1.12 TEUS
40' x 8' x 8.5'	2,720/1,360	2.00 TEUS
40' x 8' x 9.5'	3,040/1,360	2.24 TEUS
45' x 8' x 9.5'	3,420/1,360	2.51 TEUS
48' x 8' x 9.5'	3,648/1,360	2.68 TEUS
54' x 8' x 9.5'	4,104/1,360	3.02 TEUS

For container sizes not shown in this table, the equivalency will be calculated using the same concept.

ACP considers containers as cargo regardless of their contents or lack thereof. Containers that are used to transport generators, lashing gears, or that have been modified, will continue to be classified as containers and will be charged as such. A container utilized to fulfill certain tasks, other than carrying cargo, will be considered as part of the vessel's superstructure if the following criteria are met:

- Be securely welded to the deck or to the vessel's structure.

- Provide ACP Admeasurement Unit with a copy of an International Tonnage Certificate (ITC 69) or PC/UMS documentation of total volume (SS) that includes this container as part of the superstructure of the vessel.

If the volume of the container is not included in the ITC-69 or SS, the volume of the container will be included as part of the superstructure of the vessel to be reflected in the PC/UMS and an Admeasurement Service Charge will be applied according to tariff No. 1040.0000. All containers are subject to an inspection and verification by the ACP Admeasurement Unit.

For other vessels that carry containers on deck, the established PC/UMS rate is applied, in addition to the applicable per TEU charge.

It should be noted that information regarding the actual number and size of containers carried on board is critical for the correct application of toll charges to such vessels. Therefore, it is imperative that the information provided to the ACP regarding the actual number and size of containers carried on or above deck is accurate.

As part of routine inspections, ACP boarding officers will review the information provided by the vessel and, if discrepancies concerning the number and/or size of containers on board are detected, a further detailed inspection may be conducted to thoroughly verify the information. Such discrepancies could result in one or more of the following:

- Delay of transit.
- A charge to the vessel for the detailed inspection (tariff 1084.0000, see table below).
- Assessment of applicable sanctions for violations to provisions of the ACP Regulation on Navigation in Panama Canal Waters.
- Additional security inspection and escort service provided by the ACP Protection and Emergency Response Division charged to vessel.

13. Deck-loaded Containers on Ships not Built for Container Carriage

a. General

Transits with deck-loaded containers by ships not designed for container trade have become more frequent in recent years. Many of these ships are smaller general purpose, break-bulk, liquid or dry-bulk carriers. When such a ship carries deck-loaded containers well forward or aft of the bridge, the pilot's view can be obstructed, tug and locomotive sound signals can be blanketed, and risk of damage to the ship and Canal structures and equipment is increased. Failure to meet minimum visibility requirements can disrupt overall Canal operations, and can delay the vessel's transit by a day or more.

b. Approval for Transits

In some cases, vessels not meeting minimum visibility requirements may, at the discretion of the Authority, be allowed the instant transit after execution of a proper release that relieves the Authority from liability and indemnifies the Authority for damage or expenses incurred in case of damage of any sort immediately resulting from noncompliance with the visibility requirements. Additional towboats may also be assigned at the vessel's expense. Permanent waivers cannot be granted, and any future transits are expected to be in compliance with visibility requirements.

c. *Advance Notice and Inspection*

Ships not container-designed but carrying deck-loaded containers are requested to include in their Canal ETA messages information on the number and location of deck-loaded containers. As a minimum, ships should provide location of deck-loaded containers by hatch or tank; the numbers of containers loaded abeam, fore and aft, and how high they are stacked; and whether containers are oriented athwartship or longitudinally.

Such ships transiting for the first time, or that only transit occasionally with deck-loaded containers, will be checked by boarding officers or port captains or both to determine the need for visibility waivers.

Such ships transiting regularly with deck-loaded containers will be advised of any limitations on the number and configuration of deck-loaded containers necessary to satisfy minimum shipboard visibility requirements.

d. *Calculations of PC/UMS for Vessels not Designed to Carry Containers on Deck*

Panama Canal Authority admeasurers have detected on board dry bulk carriers that containers are being carried on deck. When this is detected on vessels not designed to carry containers on deck, the ACP is required to calculate the maximum on deck container carrying capacity. As such, this tonnage is added to the PC/UMS net tonnage for that vessel and it is applied to the vessel's future transits, even if it is not carrying containers on deck.

To determine the ballast or laden status for tolls at the Panama Canal, containers are considered as cargo. For a container to be considered as an integral part of the vessel, the Panama Canal Authority requires that it be permanently welded to the deck and its volume be included in the total volume of the vessel. A copy of the International Tonnage Certificate 1969 certifying this change must be sent to the Admeasurement Office.

This has been a long-standing policy which was implemented in 1952 and has been applied consistently to all vessels ever since. For this reason, dry bulk carriers reported as being in a ballast condition, but carrying containers on deck, will be assessed the laden toll rate.

14. Unauthorized Modifications to the PC/UMS Net Tonnage Certificate

- a.** Some classification societies have made minor corrections to the PC/UMS Net Tonnage Certificates for transiting vessels; such as, changes in name, call letters, flag, etc. Be advised that the PC/UMS Net Tonnage Certificates may only be altered by the Panama Canal Authority.
- b.** The practice of modifying the PC/UMS Net Tonnage Certificates, with or without the Classification Society's seal and/or stamp, is unacceptable to the Panama Canal Authority. These unauthorized modifications are grounds for invalidating the vessel's current PC/UMS Net Tonnage Certificate and, as a consequence, the Panama Canal Authority must issue a new certificate at the standard re-issue charge (Tariff No. 1040.0200).

15. Calculation of PC/UMS Net Tonnage on Passenger Vessels

- a.** For the purpose of calculating the PC/UMS Net Tonnage of passenger vessels and, thus, assessing tolls in the Panama Canal, passengers and their baggage are considered cargo; therefore, all spaces that have been identified and certified for the use or possible use of passengers are to be included in the total volume calculation of the vessel.
- b.** For the calculation of the PC/UMS Net Tonnage, the definition of "Excludable Spaces," as provided in Regulation 2, Section 5 of the International Convention on Tonnage Measurement of Ships, 1969 (ITC 69), as well as in the Maritime Regulations for the Operation of the Panama Canal, does not apply to areas on passenger vessels that are for the use of passengers. These spaces, which are designed and certified for the exclusive use of passengers, such as balconies, passageways, swimming pools, etc., are included in the total PC/UMS calculation.
- c.** In addition to the ITC-69 Certificate, passenger vessels shall provide the Panama Canal Authority with a copy of the Passenger Ship Safety Certificate. It is also recommended to present a copy of the PC/UMS documentation of total volume (Suitable Substitute) that includes the volume of all enclosed spaces, with calculation sheets sufficiently clear in order to facilitate our audit.
- d.** These documents, as well as the General Arrangement Plan, Capacity Plan with deadweight scale, Midship Section Plan, Lines Plan/Body Plan, Shell Expansion Plan, copy of the International Load Line Certificate, and copy of the Suez Canal Tonnage Certificate, should be sent to the ACP Admeasurement and Billing Unit at least four weeks prior to transit in order to review the calculations and notify the owner or representative of any discrepancies found prior to the vessel's arrival.

16. Dangerous Cargo Requirements

a. General

The Regulation on Navigation in Panama Canal Waters require a minimum of 96 hours notice of intent to transit with dangerous cargo (*ACP Navigation Regulations, Article 30*). The specific characteristics of the dangerous cargo, whether in bulk or packaged, are the primary factors which determine what, if any, precautionary measures shall be taken by the Authority. Cooperation in this matter will help in applying ACP resources for the benefit of all customers, and assure appropriate levels of safety for all vessels in transit.

b. Test of Equipment On Board

Vessels carrying dangerous materials are also required to test all dangerous cargo alarms, safety devices, and fire fighting equipment as specified in the *ACP Navigation Regulations, Article 115*. An entry shall be made in the ship's log stating that such tests were conducted and that the systems were found in proper working condition or, if not in proper order, a detailed listing of discrepancies shall be included within the log.

c. Holding Due to Non-Compliance

Vessels are also reminded that a dangerous cargo hold ("H") will be imposed on vessels not providing the required advance dangerous cargo information, and that continuing noncompliance will result in not scheduling the vessels for transit until cleared by an ACP boarding officer. This can result in a delay to the ship.

d. Tankers Claiming Cargo Tanks as "Gas Free" or "Inert"

In order to standardize the term "gas free" for applicability of the ACP Navigation Regulations, Chapter IX, Dangerous Cargo, and its interpretation when used by tankers in item GOLF of the pre-arrival radio message to the Marine Traffic Control Unit required by the *ACP Navigation Regulations, Article 30*, the following policy is established:

(1) The term "gas free" is widely used within the shipping industry and the level of being gas free has several values depending on the application. For ACP dangerous cargo regulations the definition of "gas free" requires that all cargo tanks, including cargo slop tanks, be free from dangerous concentrations of flammable or toxic gases. The goal is to have a vessel which, while in transit or at dock, is safe enough to endure a collision and not risk an explosion.

(2) To bring this definition to a working application for transiting or docking vessels, empty tanks shall be tested by the crew and verified safe for entry and hot work. When applicable, masters will report in GOLF of their pre-arrival radio message the following: **"All cargo tanks and cargo slop tanks are gas free and considered safe for entry and safe for hot work."**

(3) Vessels with inert gas systems on board shall provide the following information in paragraph GOLF of their pre-arrival radio message:

- (a) If cargo tanks have been stripped of cargo and are inert.

- (b) If the inert gas system is operational.
- (c) The last cargo carried.

e. Reporting Dangerous Cargoes in Bulk

Complete information pertaining to dangerous cargo transported in bulk aboard vessels must be provided to the Panama Canal Authority prior to entering Canal waters. It is an ACP requirement that all cargo in bulk, either liquefied-gas, liquid or solid, be reported in detail in the Ship Due form. In order to ensure efficient vessel scheduling for our customers, timely and complete information regarding dangerous cargo is of paramount importance.

Tankers shall report the cargo loading condition of each tank, to include slop and empty tanks. Specific information required includes the following:

- The amount of cargo, cargo residue or slops, as well as the inert status of each tank.
- Reports of empty tanks shall indicate last cargo, cargo residues or slops, to include the flash point.
- Reports of gas-free status shall include the following statement: "Tank is gas-free and considered safe for entry and safe for hot work." For gas-free definition, refer to subsection *d.*, *Tankers Claiming Cargo Tanks as "Gas Free" or "Inert"*.

In addition, tanker vessels carrying petroleum products or liquid chemical cargoes in bulk shall report the condition of each tank (including slop tanks and empty tanks), indicating whether such tanks are loaded with cargo, cargo residues, or are empty. This report shall include the flash point of each cargo, indicating whether the flash point temperature provided is Centigrade (°C) or Fahrenheit (°F), and whether the test method utilized to determine it was closed-cup (c.c.) or open-cup (o.c.). The flash point is used to classify the cargo and assign the precautionary-designator (PD) to the vessel. ACP requirements regarding flash point are contained in Article 30, item GOLF.6 of the Regulation on Navigation in Panama Canal Waters.

All solid bulk cargo carried aboard dry-bulk carriers or general cargo carriers shall be reported in Item GOLF of the Ship Due form. The report shall provide the technical names of the cargo in accordance with the Code of Safe Practice for Solid Bulk Cargoes (BC Code).

The aforementioned cargo information shall be reported to the Panama Canal Authority at ETA@pancanal.com, 96 hours in advance of the estimated time of arrival (ETA) of the vessel.

f. Reporting Shipments of Direct Reduced Iron

(1) Vessels transporting Direct Reduced Iron (DRI) in any of its forms, hot or cold molded briquettes, lumps or pellets, are required to report the shipment by its correct technical name and International Maritime Organization (IMO) number to the Maritime Traffic Control Unit in the vessels' advance radio messages.

(2) DRI has been classified by IMO as belonging to the "Materials Hazardous only in Bulk, MHB" class and is listed in the IMO "Code for Safe Practice for Solid Bulk Cargoes (BC), Appendix B." The IMO number for cold molded briquettes, lumps or pellets is "BC No. 15" and for hot molded briquettes is "BC No. 16."

(3) Additionally the following advance information should be provided to the Marine Chemists at Transit Operations Division, South:

(a) Copy of certification that DRI is suitable for loading.

(b) Copy of certification that DRI conforms to IMO requirements.

(c) Statement from master or shipper that IMO precautions as listed in the IMO "Code of Safety Practices for Solid Bulk Cargoes" for cold or hot molded briquettes have been followed.

(d) Copy of procedures to be followed by the ship to ensure safety of ship and cargo in the event the cargo gets wet.

g. *Precautionary Measures Due to Dangerous Cargo*

The Authority takes precautionary measures for vessels carrying dangerous cargo, which vary depending on the ship and other factors. The specific characteristics of the cargo, and whether they are in bulk or packaged, are the primary factors which determine what, if any, precautionary measures shall be taken.

Information on dangerous cargo on board shall be provided by the vessel no less than 48 hours in advance of arrival, and verified by the Authority Boarding Officer upon arrival.

Based on this information a Precaution Designator (**PD**) is assigned to the vessel. "**PDs**" are numbers (**1, 2, 3, 4, 5, 6 or 7**) or letters ("**N**" or "**H**"), where "**PD-1**" is the most hazardous and "**PD-7**", the least. "**PD-N**" means no dangerous cargo is aboard.

When a vessel does not provide the necessary information as required by the regulation, an "**H**" or "**HOLD**" is assigned. This means that the vessel will not be allowed to transit or dock until the cargo information is made available.

The "**PD**" assigned to each vessel sets forth the imposed precautionary measures due to cargo that will be taken for that vessel while in Canal waters, which include actions such as the level of pilot assignments; docking, clear-cut or channel restrictions; special precautions while at the locks, or whether or not a fire truck will stand by at the locks during lockages.

While the precautionary measures taken by the Authority are internal actions to ensure a safe transit or docking to every vessel, it is important that masters provide exact and timely information as there is a direct relationship between the type of cargo and the way the vessel is scheduled for transit or for docking at Cristobal or Balboa.

Failure to provide proper information could result in delays to the vessel.

h. Reporting Shipments of Hazardous Wastes

Vessels transporting hazardous wastes that are subject to the control of the Basel Convention on their trans-boundary movements and disposal are required to report their shipment to the Panama Canal authorities in the vessel's advance radio messages. The wastes are to be identified by correct technical name, United Nations Number and International Maritime Organization (IMO) Class and Division if applicable.

Additionally the following advance information should be provided to the Planning, Preparedness and Emergency Response Unit, Security and Emergency Response Division (e-mail: OPPD-P@pancanal.com) and to the Chemist section, Transit Operations Division, Southern District (e-mail: OPTS-Q2@pancanal.com):

- (1) Copy of a movement document, indicating the point at which the trans-boundary movement commences and the point of disposal, name of competent authorities, responsible parties and any other requirements as required by Articles 6, 11 and any other article of the Basel Convention.
- (2) Copy of Certification from shipper that the hazardous wastes are packaged and labeled in conformity with applicable IMDG (International Maritime Dangerous Goods Code) requirements.
- (3) Statements from Master that the hazardous wastes packages are stowed in accordance with applicable IMDG requirements and on his planned response procedures to be followed by the ship to ensure safety of ship and crew in the event the hazardous waste is spilled or leaked.
- (4) Proof of financial responsibility and adequate provision for indemnity covering public liability and loss to the Panama Canal Authority consistent with international practice and standards as set forth by the Treaty Concerning the Permanent Neutrality and Operation of the Panama Canal.

i. Reporting Radioactive Cargoes

(1) The International Atomic Energy Agency (IAEA) is the United Nations Agency authorized by statute to develop and promulgate regulations for the safe transport of radioactive materials. The IAEA has published its latest edition of the **Regulations for the Safe Transport of Radioactive Material, 2009 Edition, IAEA Safety Standards Series No. TS-R-1**. The IAEA regulations serve as basis for the IMO Class 7 requirements as published in the International Maritime Dangerous Goods (IMDG) Code.

(2) As such, the Panama Canal Authority requires all radioactive material shipments through the Panama Canal to comply with applicable requirements as published in the **Regulations for the Safe Transport of Radioactive Material, 2009 Edition, IAEA Safety Standards Series No. TS-R-1**.

(3) For additional or specific requirements of any radioactive material shipment, please contact the Dangerous Goods Transport Specialist at the Canal Port Captain's (Pacific) Office at:

Phone: (507) 272-4112
 Fax: (507) 272-3015
 E-Mail: OPTS-Q1@pancanal.com

j. Coverage requirements for transiting vessels carrying radioactive cargoes

(1) The Panama Canal Authority requires from transiting vessels carrying radioactive cargoes, current proof of financial responsibility and adequate provision for indemnity to third parties as a guarantee against any possible damage and/or loss to the Republic of Panama, the Panama Canal Authority, and/or any other agency, including coverage to persons, lives and property.

(2) The aforementioned insurance policies must include the Panama Canal Authority (ACP) as an *Additional Named Assured*. Considering that these insurance policies are for liability coverage, ACP may be regarded as a third party with a right to claim under that policy. As a result, the terms and conditions of the policy must clearly establish that including ACP as an *Additional Named Assured* does not preclude the ACP from presenting a claim under such policy, and does not curtail, in any way, the right of the ACP to be indemnified for any damages that may be suffered.

This requirement is not applicable to insurance policies issued by Protection & Indemnity (P&I) Clubs with respect to excepted materials.

(3) The following requirements of coverage from transiting vessels carrying specific radioactive cargoes will apply:

(a) For all IMO Class 7 (, Schedules 1-8 as listed in the IMDG Code (2004 Edition) material in excepted packages and non-fissile material in industrial packages, transiting vessels must provide either/or:

- A “coverage in full” certificate issued by any P&I Club part of the International Group, including:
 - Four-fourths (4/4) of the assured (s) liability arising out of collision with another ship, and
 - Liability for loss or damage to any fixed or floating object (FFO)

(If the “Hull & Machinery” Policy covers the above, the same must be provided) or

- A minimum amount of US\$20,000,000.00 (twenty million dollars) of liability insurance per TEU container. The Panama Canal Authority may request an increase in the amount of insurance as a result of risk evaluation made by ACP officials.

(b) For fissile radioactive material in industrial packages, and for all fissile and non-fissile radioactive material in Type A, Type B(U), and Type B(M) packages, transiting vessels must provide either/or: (For radioactive cargoes classified under IMO Class 7, Schedules 9-14 as listed in the IMDG Code (2004 Edition), transiting vessels must provide:)

- A “coverage in full” certificate issued by any P&I Club part of the International Group, including:

- Four-fourths (4/4) of the assured (s) liability arising out of collision with another ship, and
- Liability for loss or damage to any fixed or floating object (FFO)

(If the "Hull & Machinery" Policy covers the above, the same must be provided) or

- A minimum amount of US\$30,000,000.00 (thirty million dollars) of liability insurance per TEU container. The Panama Canal Authority may request an increase in the amount of insurance as a result of risk evaluation made by ACP officials.

(c) For radioactive cargoes under special arrangement or not consolidated in freight containers or any other radioactive cargo not specifically identified in this Notice, please contact our Dangerous Goods Transport Specialist at the Canal Port Captain's (Pacific) Office (507) 272-4112, or fax (507) 272-3015.

(For radioactive cargoes such as INF cargo or any other radioactive cargo not specifically identified in this Notice, please contact our chemists at the Pacific Canal Port Captain's office (507) 272-4112, or fax (507) 272-3015.)

k. Advance Notification of Shipments of Fissile Materials

(1) The Panama Canal Authority (ACP) requires a 30-day advance notification for vessels that will be transiting the Panama Canal carrying radioactive cargo containing fissile materials, which are classified under IMO Class 7 - Schedule 13.

(2) Therefore, effective immediately, vessels in this category must provide, in addition to the 30-day advance notification, full documentation of applicable certificates and technical details of the cargo in order to allow the Panama Canal Authority the opportunity to verify the compliance of the cargo with the IMDG Code (2008 Edition). Those vessels that do not comply with the advance submittal of the documentation will not be approved transit through the Panama Canal or may be subject to delays until such time that the documentation review is completed.

(3) For additional details on the required documentation mentioned above, please contact the ACP Dangerous Goods Transport Specialist at the Canal Port Captain's (Pacific) Office at telephone number (507) 272-4112 or fax (507) 272-3015.

17. Implementation of Annex II to MARPOL and Revised IBC Code

All vessels intending to transit the Panama Canal carrying Annex II liquids must have all documents required by MARPOL Annex II onboard, and use them for their voyage planning purposes.

The revised Annex II to MARPOL 73/78, as well as the amended International Code for the Construction and Equipment of Ships Carrying Dangerous chemicals in Bulk (IBC Code), require that all ships (chemical and parcel tankers, as well as dry cargo ships with deep

tanks) that are certified to carry Annex II liquids have new certificates of fitness issued, as well as comply with any other requirements under these revisions. Recognizing the threat to the environment that ships carrying Annex II liquids may pose, and conscious of its responsibility to safeguard Canal waters, the ACP determined that, in compliance with the above-referenced revisions and amendments to MARPOL, ships affected by these amendments must be in full compliance.

In order to expedite the verification process of the compliance with the new or updated certification by the above-mentioned ships, operators are encouraged to submit to the Panama Canal Authority (ACP) in advance, preferably electronically, the following documents for each one of their vessels:

- a. New or updated Certificate of Fitness;
- b. Updated List of Annex II Cargoes that may be carried by subject vessel; and
- c. International Pollution Prevention Certificate for vessels that intend to carry only Noxious Liquid Substances.

In addition to the above-mentioned documents, all chemical and parcel tankers and dry cargo ships with deep tanks, arriving with Annex II regulated cargo, are requested to provide, at least ninety-six (96) hours prior to their arrival at Panama Canal waters, their stowage plans, as well as the name of their last loading port and the departure date from that port. These notifications shall be forwarded to:

Chemist, Transit Operations Division
Operations Department
Telephone: (507) 272-4112
Fax: (507) 272-3015
E-mail: opts-q1@pancanal.com

Vessels that do not fully provide the requested documentation and information in advance may be subject to unnecessary delays or denial of transit, since the verification process will be done only after the documentation and information has been received in the above listed ACP office. Non-compliance with the requirements listed in the Amendments to Annex II of MARPOL 73/78 will be considered a violation of the Panama Canal Authority Maritime Regulations for the Operation of the Panama Canal.

18. Pre-arrival Cargo Declaration, Security Inspection and Escort

a. Vessels intending to arrive at Panama Canal waters must declare all cargo carried on board at least 96 hours prior to their arrival. Vessels that arrive from ports that are less than 96 hours away are required to submit revisions to their original cargo declarations as may be necessary in order to provide updated cargo information. Exceptions to this requirement are:

- Bins (standard-size open top containers) or any other receptacles (not containers) that are carried on deck to store equipment that is not welded or spot welded. The vessel's

master must declare the information regarding these items to ACP boarding officers upon arrival at Panama Canal waters.

- Vessels intending to transit transporting radioactive material that is classified under IMO Class 7 – Schedule 13, shall provide a 30-day advance notification, as required by Article 137 of the Regulation on Navigation in Panama Canal waters.

ACP boarding officers will verify cargo information submitted in the pre-arrival notification and discrepancies with the cargo manifest presented by the master will be reported to the ACP Protection and Emergency Response Division. These discrepancies will be evaluated and may lead to the application of security control measures as deemed necessary by the ACP. These control measures may include, but not be limited to one or more of the following:

- Direct communication with the vessel's master to clarify any discrepancies or any other security related issues,
 - Delay of transit,
 - The assignment of additional resources,
 - The escorting of the vessel,
 - Fines

All additional resources provided by the Canal on account of discrepancies identified during the verification of the cargo declaration will be charged to the vessel. Notwithstanding the above, the discrepancies detected shall be corrected and submitted through the ACP Electronic Data Collection System (EDCS) before the vessel departs to sea. Failure to do so may result in a notification being sent to the Port Facility Officer of the next port of call, as well as in an increase to the vessel's assigned security level the next time the vessel is presented for transit.

b. The ACP established additional security inspection and escort services to vessels that fail to comply with the 96-hour pre-arrival notice, or that submit their pre-arrival notice with wrong or missing information. The Canal Protection Inspection and Escort Tariff will be applied as follows:

- A vessel inspection may be triggered due to:
 - 96-hour regulations non-compliance,
 - Wrong or missing information in Ship Due, Crew List or Passenger List, and
 - Requirement by Panamanian authorities.

An escort may be triggered at any moment after a Canal Protection Inspection, if the inspection corroborates the non-compliance with ACP security and protection regulations.

The ACP will continue to verify the EDCS submitted cargo declaration vs. the cargo manifest provided by the master. If discrepancies are detected, the vessel's operator and/or

shipping agent will be contacted to coordinate the correction of the submitted data. This data shall be corrected within 96 hours from the time the discrepancies are detected and reported. The following information is to be verified:

- The total weight of cargo on board declared on the Ship Information and Quarantine declaration will be compared with the weight declared on EDCS. A percentage of tolerance and tare weights will be applied to offset differences due to diverse information origin (including departure from ports within 96 hours to Panama Canal Waters) and container weight.
- Total container units on board. For vessels with cargo movements after boarding inspection, the Master will declare amount of containers to be loaded and discharged.

If the information is not corrected during the provided time period, a report will be filed to ACP Protection and Emergency Response Division in order to be included in the risk assessment matrix for that vessel. This could lead into a security inspection and/or escort of the vessel during her next transit.

19. Hot Work Performed On Board Vessels

a. Hot work is defined as any type of work that involves open flames or that generates sparks, such as welding, grinding, drilling, and cutting. This work can be performed in open or in confined spaces.

b. A confined space is an enclosed space that:

- (1) is of sufficient size that someone can bodily enter to perform an assigned task;
- (2) has limited or restricted means of entry or exit, making it difficult to escape in an emergency;
- (3) is not designed for personnel to occupy continuously; and
- (4) does not have natural ventilation.

c. In order to ensure safe conditions, before any hot work is performed in Panama Canal waters, a written request for authorization of the site (i.e. anchorage, berth, dock) accompanied by a Marine Chemist's Certificate approving the intended hot work shall be forwarded to the Canal Port Captain's office (facsimile 272-5280).

d. For the ACP to consider this request, the Marine Chemist's Certificate shall be legible and shall include the following as a minimum:

- (1) A unique numeric or alphanumeric identifier for the certificate.
- (2) Name, SIN and or IMO of vessel.
- (3) Type of vessel.
- (4) Vessel's owner or agent or responsible party.

- (5) Requester's name, phone, and facsimile number.
 - (6) Vessel's actual location.
 - (7) A description of type and extent of the work to be performed.
 - (8) A sketch or list of adjacent spaces, valves, piping, coils, or other shipboard components that may be affected by the hot work.
 - (9) Tests and inspections done on the space to be worked in, adjacent spaces, and appurtenances. As a minimum, measurements of oxygen, combustible, and toxic gases shall be reported for each space. These requirements are especially important if the hot work is to be performed within or on the boundaries of a confined space.
 - (10) Date and time inspection was completed.
 - (11) Frequency of required re-inspections by a competent person.
 - (12) Conditions under which the Marine Chemist shall be consulted or recalled.
 - (13) Any additional requirements, limitations or restrictions (such as fire watch, ventilation, or lock out & tag out), if any.
 - (14) The applicable NFPA 306 Standard Safety Designation(s).
 - (15) The Marine Chemist's name, signature, and license number.
 - (16) Signature for receipt of the Marine Chemist's Certificate by the requester or authorized representative, signifying the understanding of the conditions, and the limitations and requirements for maintaining conditions under which it is issued.
- e.** The ACP will refuse requests if Marine Chemist's Certificate does not comply with the above or if any other element of the request is deemed inadmissible.
- f.** The hot work, limited to the scope set forth on the corresponding Marine Chemist's Certificate, shall only commence once the ACP issues a written authorization of the site to the requester.
- g.** The authorization of the site shall not be construed as an endorsement by the ACP of the Marine Chemist's Certificate.
- h.** If the scope, site and/or conditions change, the hot work shall not be performed unless a new authorization of site is obtained from the ACP, by submitting a new request for authorization of the site accompanied by a Marine Chemist's Certificate with updated information.
- i.** The Marine Chemist certificate approving the hot work as well as the authorization of site issued by the ACP shall be securely posted in a conspicuous place aboard the vessel before the work is started.
- j.** Failure to partially or totally comply with these requirements will result in one or more of the following:

- (1) Denial of authorization of the site to perform hot work
- (2) Termination of hot work
- (3) Penalties
- (4) Fines

20. Manning Requirements

Vessel agents and their principals should remind ships' personnel that sufficient personnel must be available for a safe operation while in Canal waters. The Transit Operations Division Executive Manager, or his designee may deny transit if, in his opinion, the vessel is insufficiently manned. These requirements include:

- (1) A full watch on deck and in the engine room while underway in Canal waters.
- (2) Sufficient officers and crew members forward and aft to handle lines expeditiously when approaching a lock, while moored temporarily to a lock wall, when in a lock chamber, or when so requested by the pilot.
- (3) Sufficient seamen to receive and let go tug lines.
- (4) When a vessel is entering or leaving a lock, getting underway, berthing, shifting berth, anchoring, or is underway in Gaillard Cut, the master shall be on the bridge and all other officers shall be at their regular stations.
- (5) As otherwise required by the *ACP Navigation Regulations, Articles 102 to 106*.
- (6) Should Canal officials or the vessel's agent require the master's presence or attention, the request may be granted by the pilot provided the master's presence is not momentarily essential and a qualified representative remains on the bridge. The master shall remain or return to the bridge at the pilot's request.

21. Additional Pilots due to Vessel Deficiencies

a. Some vessels arriving for transit with certain noted deficiencies or conditions have required the assignment of additional pilots in order to allow them to complete their transit. In the past, the cost of these additional pilots was absorbed by the Panama Canal; however, in light of increasing costs, the Panama Canal Authority now finds it necessary to charge for these additional resources.

Any vessel that requires the assignment of more pilots than the number that would normally be required by a vessel of her size is assessed additional pilotage fees in accordance to established tariffs for:

- Pilots assigned before transit begins.
- Pilots assigned due to late discovery of deficiency.

Some deficiencies or conditions that could require additional pilots are:

- Restricted visibility (excluding full-container vessels)
- Inadequate sanitary facilities
- Inability to relay
- Clear channel restrictions due to cargo or ship design
- Inability to develop and maintain the minimum *full ahead* speed required to complete the transit in standard times.

b. In addition, handlines using transit advisors instead of pilots, which are unable to complete their transit on the same day, are assessed the tariff for transit delay for the additional transit advisor.

Whenever owners or representatives of handline vessels that would normally transit with transit advisors request the assignment of a regular pilot instead, that assignment is charged at the rate specified in Tariff 1060.0040, if sufficient notification has been provided; or otherwise, at the rate specified in Tariff 1060.0045.

Whenever handline vessels present some deficiency or condition that prevent the completion of their transit as scheduled, they are assessed the tariff for transit delay and other related charges, such as launch and moorage.

Whenever owners or representatives of handline vessels request to stop in the Canal interrupting their transit, they are assessed the tariff for transit delay and other related charges, such as launch and moorage. However, if a transit is interrupted due to Canal scheduling considerations, these charges will not be applied.

22. Main Source of Electrical Power

a. The main source of electrical power shall have sufficient capacity to supply all auxiliary services necessary for maintaining transiting vessels in normal operational and habitable conditions without recourse to the emergency source of electrical power.

b. This main source of electrical power shall consist of at least two generating sets, one acting as back-up, to ensure that the vessel remains capable of supplying those services necessary to continue normal operational conditions of propulsion, maneuverability and safety.

c. To comply with SOLAS requirements, the generating sets shall also supply the power to enable permanent minimum comfortable conditions of habitability, which include adequate services for cooking, heating, domestic refrigeration, mechanical ventilation, sanitary and fresh water. (1974/78 SOLAS, II-1, D-40 and 41.)

23. Emergency Source of Electrical Power

- a. The emergency source of electrical power may be either a generator or an accumulator battery.
- b. The electrical power available shall be sufficient to supply all those services that are essential for safety in an emergency, due regard being paid to such services as may have to be operated simultaneously.
- c. The emergency source of electrical power, associated transforming equipment, emergency switchboard and emergency electric lighting must comply with SOLAS 2004, Reg.II-1/42 through 45 as it applies.

24. Sanitary Facilities and Sewage Handling

- a. Vessels transiting the Canal should have suitable sanitary facilities for the pilot(s). This is particularly important for barges, hand lines and other vessels which are not normally so equipped and whose progress is slow. Vessel shall also have sanitary facilities for the intended use of the Canal deckhands on deck or close to their working areas, and must be in suitable sanitary conditions. In case there are no sanitary facilities close to the deckhands working area, or the existing ones are kept in poor conditions, vessel shall make proper arrangements to provide one, in good conditions, when requested.
- b. If a transiting ship does not have adequate sanitary facilities, the interval for which each pilot is assigned will be shortened, and significant delays could result.
- c. Ships are required to be equipped with one of the following sewage systems:
 - (1) A sewage treatment plant which shall be of a type approved by the Administration, in compliance with the standards and test methods of Resolution MEPC.2(VI); or
 - (2) A sewage comminuting and disinfecting system approved by the Administration; or
 - (3) A holding tank, with a capacity to the satisfaction of the Administration, for the retention of all sewage, having regard to the operation of the ship, the number of persons on board and other relevant factors.
- d. Discharge of sewage is strictly prohibited into all water bodies under the responsibility of the Panama Canal Authority. Sewage overboard discharge valves must be clearly mark, close and secured by padlocks or other approved method when ships enter the Panama Canal Pacific Anchorage or Atlantic Anchorage areas, and must remain as so until vessel departs from Panama Canal Authority's waters.

25. Discharging of Vessel Wastes, Oily Bilge Water and Ballast Water

In compliance with ACP Sanitation Regulations, Article 40:

(1) Vessels shall not discharge or throw into Panama Canal waters any ballast, ashes, boxes, barrels, straw, paper or other solid matter, including garbage; nor discharge heavy slops, engine or fire room bilge water, oil, radioactive substances, or any other contaminating substances.

(2) Before arrival at a port in Canal waters, vessels shall dispose of all waste in a manner consistent with the requirements of the International Convention for the Prevention of Pollution from Ships 73/78 (MARPOL) and all amendments thereto. If unable to dispose of waste at sea, vessels may use the services available for such purpose.

(3) Ballast tanks shall not be discharged into Canal waters. Vessels wishing to load or unload ballast must have properly fitted chutes or spouts, built and located in such a way that the ballast is not spilled overboard.

(4) Incineration of wastes on board ships is specifically prohibited in Canal waters, in compliance with MARPOL, Article 5 of the 1996 Protocol.

26. Emergency Escape Breathing Devices

a. The minimum number of EEBDs to be kept within accommodation spaces should be as follows:

(1) For cargo ships: two (2) EEBDs and one (1) spare EEBD;

(2) For passenger ships carrying not more than 36 passengers: two (2) EEBDs for each main vertical zone and a total of two (2) spare EEBDs; and

(3) For passenger ships carrying more than 36 passengers: four (4) EEBDs for each main vertical zone and a total of two (2) spare EEBDs.

b. In machinery spaces for category A containing internal combustion machinery used for main propulsion, EEBDs should be positioned as follows:

(1) One (1) EEBD in the engine control room, if located within the machinery space;

(2) One (1) EEBD in workshop areas. If there is, however, a direct access to an escape way from the workshop, an EEBD is not required; and

(3) One (1) EEBD on each deck or platform level near the escape ladder constituting the second means of escape from machinery space (the other means being an enclosed escape trunk or watertight door at the lower level of the space).

c. For machinery spaces of category A other than those containing internal combustion machinery used for main propulsion, one (1) EEBD should, as a minimum, be provided on each deck or platform level near the escape ladder.

27. Smoking Prohibition in Canal Waters

Pursuant to the Regulation on Sanitation and Communicable Disease Prevention, the ACP has prohibited smoking in enclosed areas on vessels in Panama Canal waters in the presence of ACP officials performing their duties. This directive modified the Administrator's Directive, which established the prohibition to smoke in all ACP installations and equipment, but excluded vessels within Panama Canal waters.

The ACP has adopted general provisions of the National Health Authority and recommendations of the World Health Organization (WHO), as well as those deriving from international conventions to which Panama is a party, in order to ensure the health and safety of the employees of the ACP.

28. Proper Display of the Panamanian Flag

The Panama Canal Authority Regulation on Navigation in Panama Canal Waters, Article 26, Section Four, Chapter I, Requirements and prohibitions, states that "All vessels shall display the Panamanian flag from dawn to 1800 hours while they are in Panama Canal waters, and may also display their national and house flags."

The following information governs the proper manner in which to display the Panamanian flag on vessels while in Panama Canal waters, including its anchorages.

The Panamanian flag is divided into four rectangles of equal size. The top two quadrants are white with a five point blue star in the center on the hoist side and plain red. The bottom two quadrants are plain blue on the hoist side and white with a five point red star in the center.

The flag must be displayed with the white quadrant with the blue star on top, adjacent to the flagpole, leaving the blue quadrant directly below and also adjacent to the flagpole.

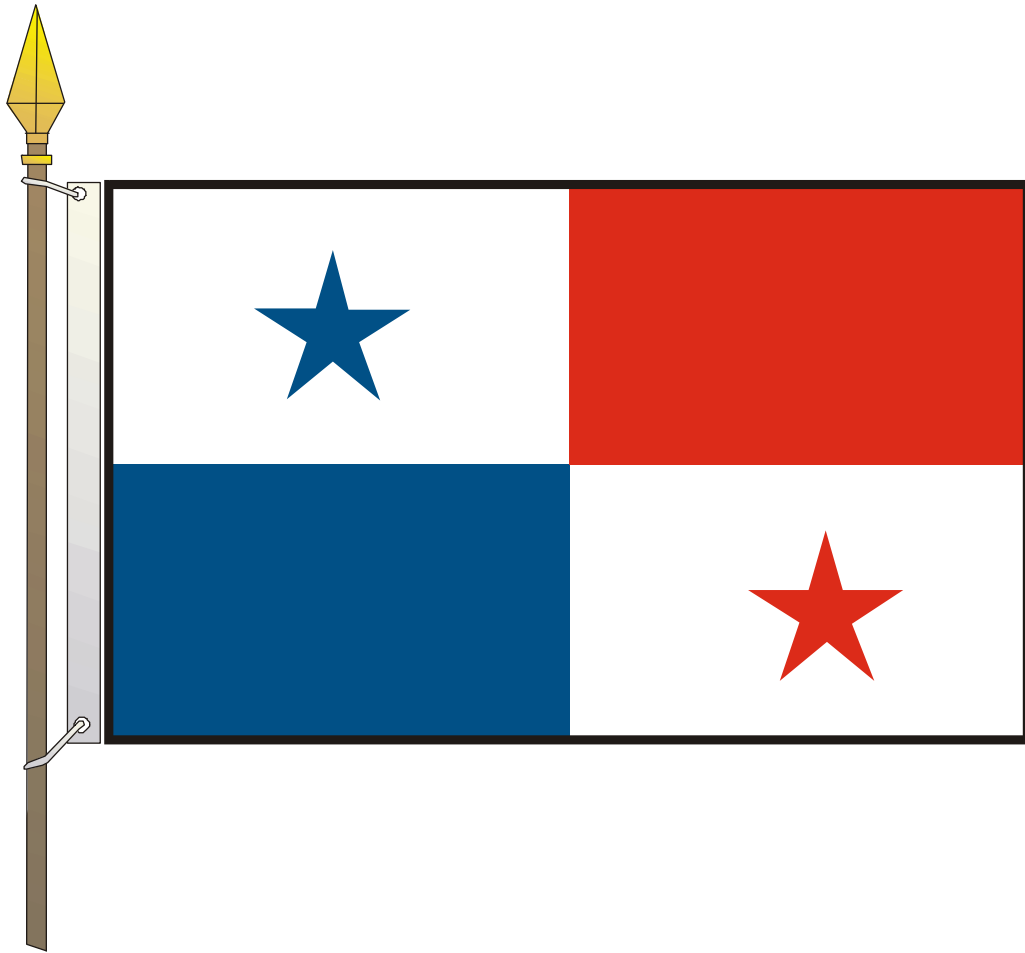

ANNEX 1

Embarking or Disembarking During Transit

a. The Panama Canal Authority (ACP) does not provide commercial launch services on a regular basis at this time. However, under special circumstances, and in exceptional cases, embarking and disembarking may be accommodated. The operation will take place only after approval by the Canal port captain on duty on the side of the Isthmus under his supervision. These services will entail a charge, unless otherwise authorized as official or courtesy.

b. Passengers and crew members aboard vessels, agents, agents' representatives, vessels' contractors or ACP employees or others on Official or Courtesy transits, utilizing Authority launch service **without** a service charge, will only be permitted to embark or disembark from transiting vessels in the Canal at the Balboa Basin at the Pacific terminal (Diablo Landing), Gamboa at Chagres Crossing (Gamboa Landing), and Gatun Lake Landing at the Atlantic terminal. The number of personnel should be limited and large groups avoided.

c. Designation of these sites by the Executive Vice President for Operations is based on safety and operational considerations. Every effort will be made to limit the use of the Gamboa Landing for official Canal business due to facilities and resource limitations. Pilots, towboat personnel, line handlers, and other Authority employees on duty will be governed by operational requirements when performing their official duties.

d. *Subject to operational and safety considerations, the following are exceptions to the above rules:*

(1) Personnel utilizing Authority launch service **with** a service charge, may also embark or disembark a transiting vessel at the Balboa or Cristobal anchorages and the Mine Dock.

(2) In cases of dire need or an emergency, personnel may also embark or disembark at the locks. This will require previous approval of the Transit Operations Division executive manager who will provide authorization on a case-by-case basis.

(3) Prevailing tariff rates will apply to ACP launch service and for gangway handling when embarking or disembarking at the locks. Shipping Agents will be charged based on CPC approval.

e. *When embarking or disembarking at the locks is authorized:*

(1) Permission will be communicated by MTC to the appropriate control house operator and the Admeasurement Unit manager.

(2) Each occasion that a gangplank is secured to a vessel, the operations supervisor will notify the Admeasurement Unit and district port captain.

(3) The message must name the person or persons and baggage or packages involved and the steamship agency requesting the service.

(4) Only those person(s) and material identified and approved will be permitted to be embarked or disembarked.

f. Steamship agents will make arrangements with the government customs and immigration offices whenever required.

g. *Use of Davis and Paraiso landings:*

(1) These facilities are not suitable for use by the general public. They were constructed only as work areas with no controlled access or contraband control measures.

(2) Due to the movement of tugs and the maneuvering of ships in these areas, boarding is more complex than normal. The close proximity to the locks normally makes it impractical to use the accommodation ladder, leaving only the pilot ladder.

(3) With the exception of pilots assigned to transiting vessels or going to or from the tie-up station, admeasurers measuring vessels, Transit Operations Division personnel and line handlers assisting transiting ships, boarding of vessels in these areas by Authority employees requires specific approval by the Transit Operations Division executive manager.

(4) These facilities are not to be used by non-Authority personnel for embarking/disembarking vessels in transit except when absolutely necessary due to an emergency. In these cases, it requires the specific approval of the Transit Operations Division, who will have to determine that the emergency is such that it precludes the use of one of the other sites designated for that purpose.

h. *Weapons in Authority buildings and facilities.*

The carrying of weapons within Authority buildings and facilities is prohibited, except in the case of law enforcement officials or employees of the Authority who are authorized to carry weapons in the performance of their official duties. Exceptions to this regulation must be approved by the Protection and Emergency Response Division manager.

i. Ship's business and commercial enterprise activities should be conducted in the ports or in the anchorage areas using PMA equipment.

ANNEX 2

All Locks Composite Maximum Clearances

- GENERAL NOTES**
- SEVERAL MISC. PORTABLE STRUCTURES (SUCH AS: PERSONNEL SHELTERS, WATER COOLER SHEDS, HANDRAILS, VENTILATOR HOODS, ETC.) ARE OBSTRUCTING ON SIDEWALLS. THESE CAN BE READILY REMOVED.
 - LAMP STANDARDS CAN BE LOWERED OR REMOVED READILY.
 - DASH LINES INDICATE VERTICAL OBSTRUCTION VARIATIONS DUE TO CHANGES IN TIDE AND OR WATER LEVEL.
 - RANGE TOWER AT GATUN IS 22.0 FROM FACE OF WEST LOCK WALL. VERTICAL CLEARANCE REQ'D = 36.37.

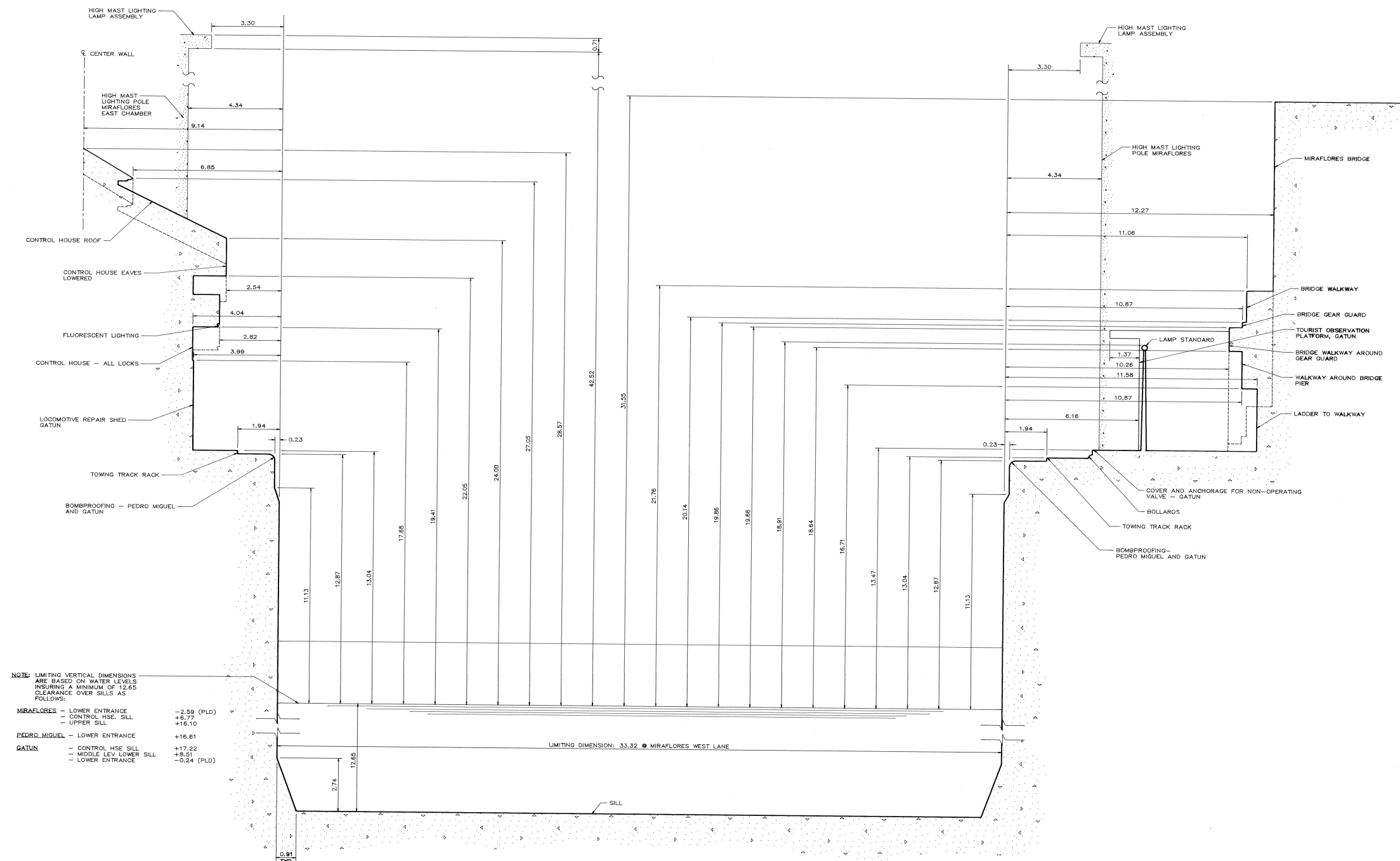

NOTE: LIMITING VERTICAL DIMENSIONS ARE BASED ON WATER LEVELS INSURING A MINIMUM OF 12.65 CLEARANCE OVER SILLS AS FOLLOWS:

MIRAFLORES	- LOWER ENTRANCE	-2.59 (PLD)
	- CONTROL HSE. SILL	+6.77
	- UPPER SILL	+16.10
PEDRO MIGUEL	- LOWER ENTRANCE	+16.61
GATUN	- CONTROL HSE SILL	+17.22
	- MIDDLE LEV LOWER SILL	+8.51
	- LOWER ENTRANCE	-0.24 (PLD)

DIMENSIONS IN METRIC SYSTEM

JOB SAFETY DEPENDS ON YOU

PANAMA CANAL COMMISSION	
ENGINEERING AND CONSTRUCTION BUREAU	
ENGINEERING DIVISION	
BALBOA HEIGHTS, REPUBLIC OF PANAMA	
ALL LOCKS	
COMPOSITE MAXIMUM CLEARANCES	
ALL LOCKS PANAMA	
LIMITING DIMENSIONS	
GENERAL NOTES AND SECTION.	
SCALE: 1:75	DATE: AUGUST 28, 1991
DESIGNED: RGJ / LB	SUBMITTED: <i>[Signature]</i>
DRAWN: R. HAWKINS R.	APPROVED: <i>[Signature]</i>
CHECKED: <i>[Signature]</i>	APPROVED: <i>[Signature]</i>

SUPERSEDS SAME DWG. 5044-424, DATED 10-17-63

5044-424 SHEET 1 OF 2